

# PROPOSED "CONVENIENCE STORE & GAS STATION"

LOCATED AT  
1001 W VILLA MARIA RD, BRYAN, TX 77801

ISSUE FOR:  
FOR INTER REVIEW ONLY   
BID ONLY   
PERMITS SET   
CONSTRUCTION SET

REVISIONS:		
NO.	DATE	DESCRIPTION

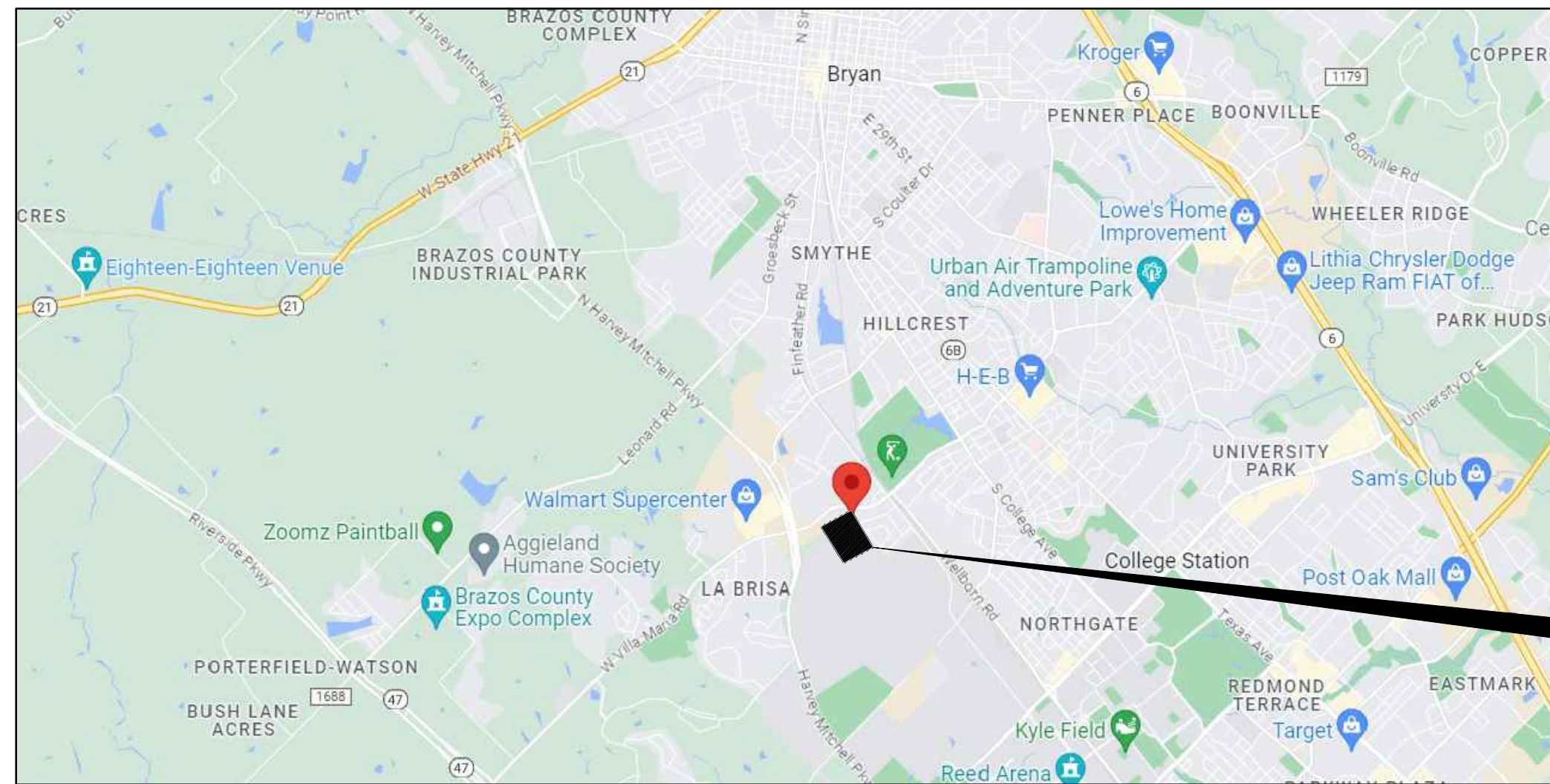
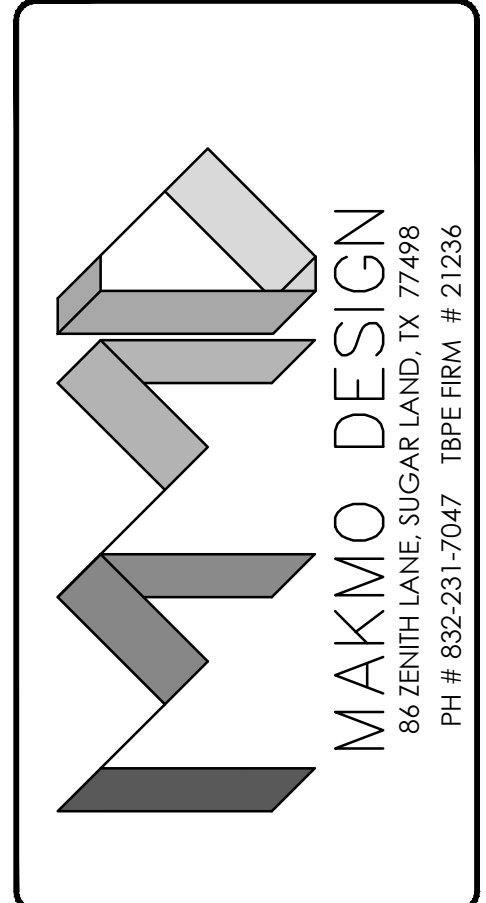

VICINITY MAP  
N.T.S

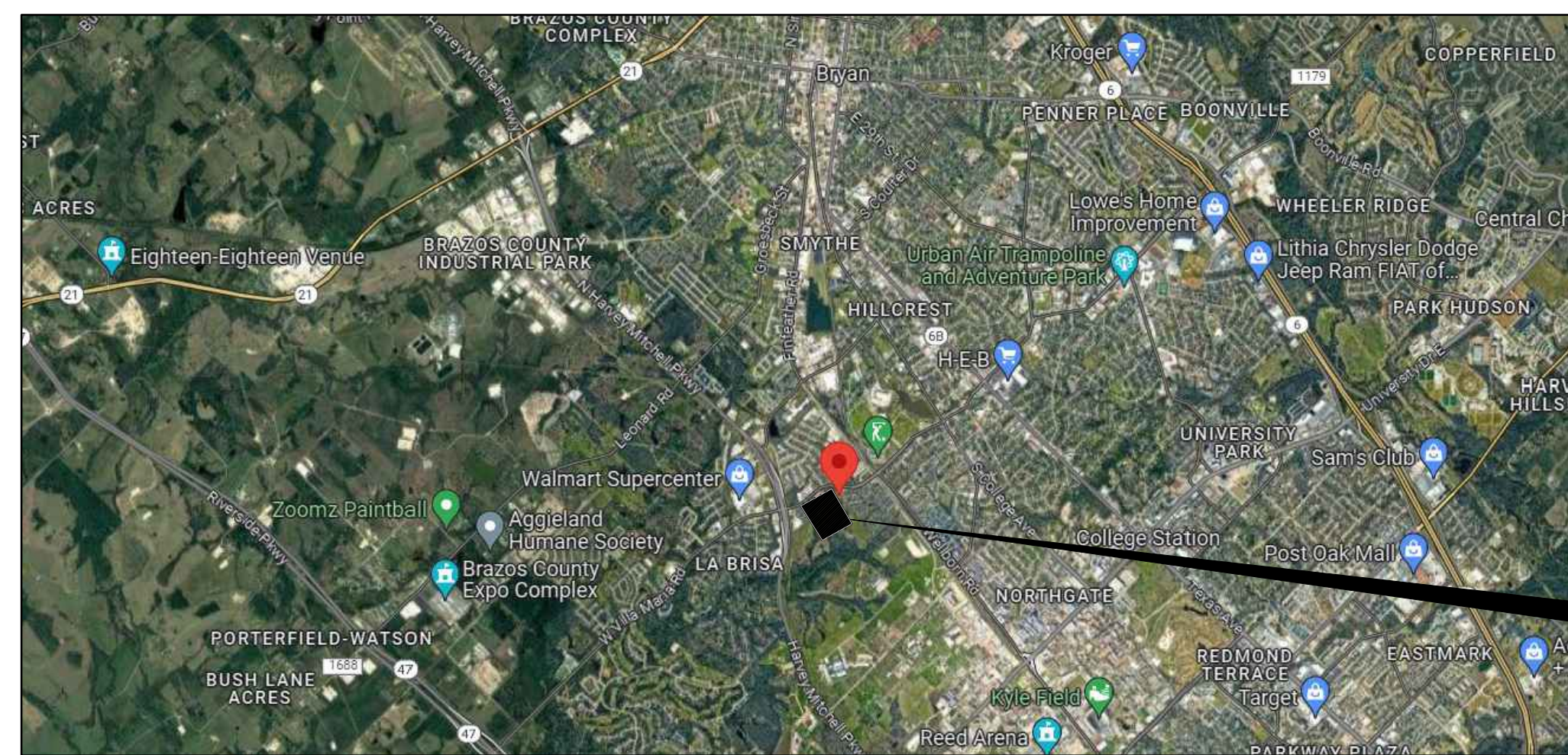

PROJECT LOCATION  
N.T.S

### PROJECT DESCRIPTION

PROJECT NAME : PROPOSED C-STORE & GAS STATION  
 LOCATION : 1001 W VILLA MARIA RD, BRYAN, TX 77801  
 PROJECT DESCRIPTION : A GROUND UP CONSTRUCTION OF A ONE STORY C-STORE BUILDINGS 7,136 SQ.FT

### SHEET INDEX

- CIVIL
- C-0.0 COVER SHEET
  - C-0.1 TOPOGRAPHIC SURVEY
  - C-1.0 SITE PLAN
  - C-2.0 GRADING PLAN
  - C-2.1 DRAINAGE PLAN
  - C-2.2 DRAINAGE CALCULATIONS
  - C-2.3 SITE SECTION
  - C-3.0 EROSION AND SEDIMENT CONTROL PLAN
  - C-4.0 UTILITY PLAN
  - C-5.0 PAVING PLAN
  - C-6.0 SITE DETAILS
  - C-6.1 CONSTRUCTION DETAILS
  - C-6.2 SWPPP DETAILS

DEVELOPMENT AREA	
TOTAL ACREAGE	= 2.43 ACRES
PROPOSED DEVELOPMENT	= 2.43 ACRES
TYPE OF DEVELOPMENT	= 1 STORY BUILDING

FLOOD PLAN INFORMATION			
F.I.R.M. NO.	48041C	PANEL	0215F
EFFECTIVE DATE	04-02-2014	ZONE	"X"
FLOOD INFORMATION PROVIDED HEREON IS BASED ON SCALING THE LOCATION OF THE SUBJECT TRACT ON THE FLOOD INSURANCE RATE MAPS. THE INFORMATION SHOULD BE USED TO DETERMINE FLOOD INSURANCE RATES ONLY AND IS NOT INTENDED TO IDENTIFY SPECIFIC FLOODING CONDITIONS. WE ARE NOT RESPONSIBLE FOR THE F.I.R.M.'S ACCURACY.			

**PROPOSED C STORE & GAS STATION**  
LOCATED AT  
**1001 W VILLA MARIA RD, BRYAN, TX 77801**

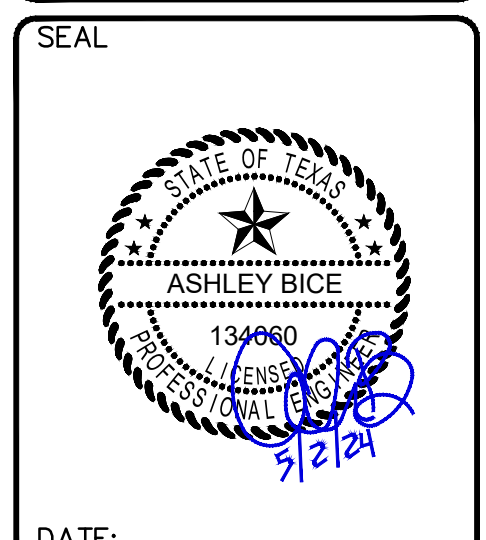

PROJECT NUMBER	23-000
SCALE	N/A
DRAWN BY	R.R
CHECKED BY	A.Z
SHEET TITLE	:

**COVER SHEET**

DRAWING NUMBER:  
**C-0.0**

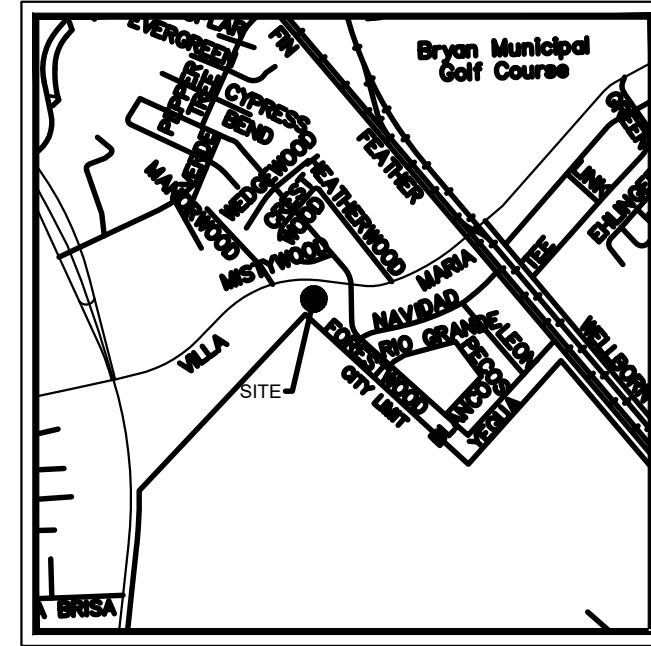

LOCATION MAP  
NTS

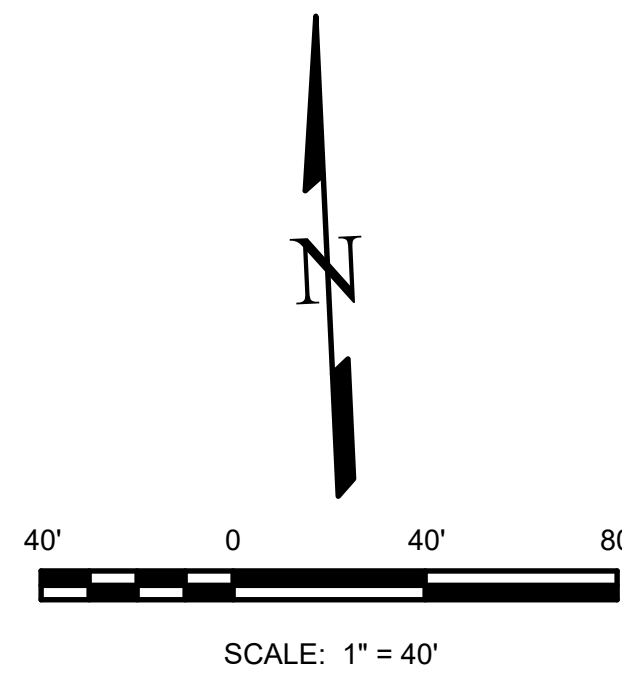

TOVM LTD  
LOT 78 BLOCK 18  
CITED 2.942 ACRES  
CASA MARIA SUBDIVISION  
13462 / 005 ORBCT

LANA MARINA RENEE, DVM  
WESTERN NATIONAL BANK SUBDIVISION  
LOT 1 CITED 1.47 ACRES  
7212 / 014 ORBCT

MOMIN MUSHTAQALI & ADIL R. MOMIN  
WESTERN NATIONAL BANK SUBDIVISION  
LOT 2 CITED 2.43 ACRES  
16358 / 247 ORBCT

THE TEXAS A&M UNIVERSITY SYSTEM  
TRACT 1 CITED 191.68 ACRES  
16358 / 247 ORBCT

GENERAL SURVEY NOTES:

- MONUMENTATION AS SHOWN.  
● 1/2" ROD FOUND
- BASIS OF BEARINGS UTILIZED IS THE TEXAS STATE PLANE COORDINATE SYSTEM, CENTRAL ZONE 5376, NAD 83. BEARINGS & DISTANCES CITED HEREON ARE SHOWN AS FOUND OR MEASURED WITH THE RECORDED OR PUBLISHED BEARINGS & DISTANCES SHOWN AS REFERENCE.
- FIELD SURVEY COMPLETED ON NOVEMBER 11, 2022.
- THE PHYSICAL ADDRESS FOR THE PROPERTY SHOWN HEREON IS 1101 W VILLA MARIA ROAD, BRYAN, TEXAS, 77801.
- ALL ABOVEGROUND PHYSICAL AND VISIBLE IMPROVEMENTS ARE SHOWN HEREON INCLUDING BUT NOT LIMITED TO FENCING, CONCRETE SIDEWALKS, POWER POLES, UTILITY METER BOXES OR VAULTS, CONCRETE DRIVEWAY APRONS AND BOLLARDS POSTS. THERE EXISTS A STAND OF MIXED HARDWOOD TREES IN THE LOWER SOUTHEAST PORTION OF THE TRACT; A TREE SURVEY WAS NOT A PART OF THIS SURVEY PRODUCT THEREFORE NO TREE SPECIMENS ARE SHOWN HEREON.
- THIS PLAT SHALL NOT BE CONSTRUED TO REPRESENT A BOUNDARY SURVEY.
- THE OFFICIAL PLAT FOR WESTERN NATIONAL BANK SUBDIVISION IS RECORDED UNDER CLERK'S FILE NO. 1982-223459, ORBCT OR VOL. 517, PG. 707, MRBCT.
- ABOVEGROUND VISIBLE UTILITIES SHOWN HEREON ARE THE RESULT OF EVIDENCE COLLECTED AS PART OF AN ON-THE-GROUND SURVEY ONLY. NO UTILITY MAPS WERE PROVIDED BY ANY UTILITY COMPANY OR THE CITY OF BRYAN, NOR WAS A TEXAS 811 CALLED INITIATED. SURVEYOR MAKES NO GUARANTEE THAT THE UTILITIES SHOWN HEREON COMPRISE ALL FEATURES ON THE SUBJECT TRACT, EITHER IN SERVICE OR ABANDONED.
- ACCORDING TO FEMA FLOOD INSURANCE RATE MAP PANEL NO. 48041C215F DATED APRIL 2, 2014 FOR THE CITY OF BRYAN, BRAZOS COUNTY, TEXAS, THE PROPERTY SHOWN HEREON APPEARS TO LIE WITHIN ZONE X, AN AREA OF MINIMAL FLOOD HAZARD. THIS DETERMINATION IS MADE UTILIZING PUBLISHED DIGITAL IMAGERY AND SCALING FROM AFOREMENTIONED FEMA MAP PRODUCTS. NO ELEVATION CERTIFICATE WAS PREPARED AT THE TIME OF THIS SURVEY.
- ORBCT DENOTES OFFICIAL RECORDS OF BRAZOS COUNTY, TEXAS; P.O.B. DENOTES POINT OF BEGINNING; DRBCT DENOTES DEED RECORDS OF BRAZOS COUNTY, TEXAS; MRBCT DENOTES MAP RECORDS OF BRAZOS COUNTY, TEXAS.

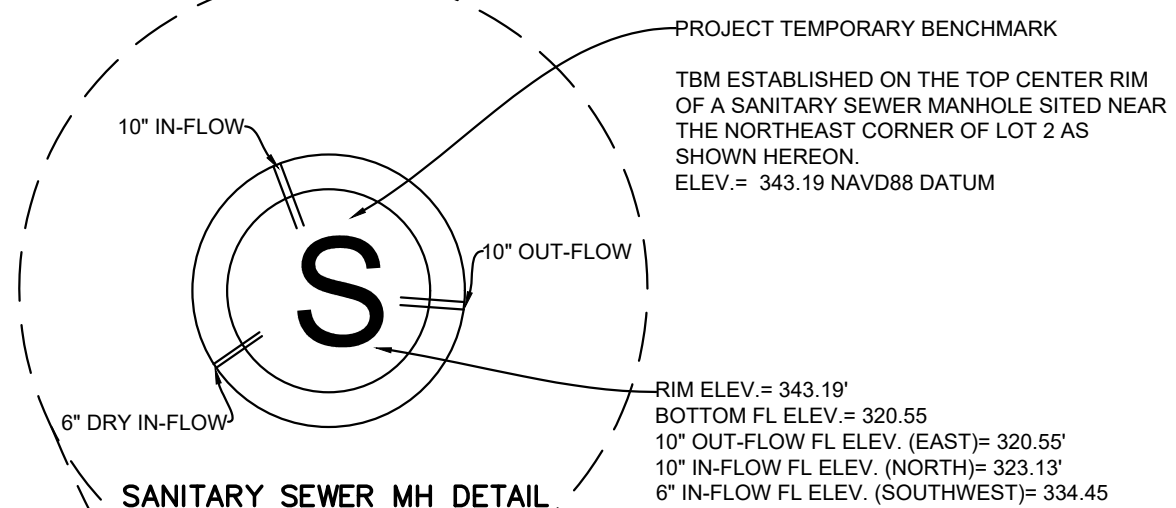

LEGEND

- = CLEANOUT
- = ELECTRIC METER
- = GAS VALVE
- = IRRIGATION CONTROL VALVE
- = STORM MANHOLE
- = SANITARY MANHOLE
- = UTILITY POLE
- = SIGN
- = CABLE TV SERVICE PEDESTAL
- = TELEPHONE PEDESTAL
- = WATER METER
- = WATER VALVE
- = WOOD FENCE
- = CHAINLINK FENCE
- = SANITARY SEWER LINE
- = OVERHEAD ELECTRIC

L1 S 85°44'31" E 174.32'  
PLAT CALL: S 83°03'54" E 174.32'

C1 RADIUS= 25.00'  
ARC= 38.37'  
Δ= 87°26'15"  
PLAT CALL R= 25.00'

L2 S 02°10'15" W 248.36'  
PLAT CALL: S 04°50'50" W 248.36'

C2 RADIUS= 330.00'  
ARC= 172.22'  
Δ= 29°44'03"  
PLAT CALL R= 330.00'

SURVEYOR'S CERTIFICATION:

To: MUSHTAQALI MOMIN & ADIL R. MOMIN AND/OR THEIR ASSIGNS:

I HEREBY CERTIFY THAT THIS SURVEY WAS MADE ON THE GROUND BY ME OR UNDER MY DIRECT SUPERVISION OF THE PROPERTY SHOWN HEREON, THERE WERE NO ABOVEGROUND VISIBLE ENCROACHMENTS OBSERVED AT THIS TIME EXCEPT AS SHOWN HEREON AND THAT THIS PLAT CORRECTLY REPRESENTS THE FACTS FOUND AT THE TIME OF SURVEY TO THE BEST OF MY KNOWLEDGE AND BELIEF, THAT THIS PLAT SUBSTANTIALLY COMPLIES WITH REQUIREMENTS FOR A TEXAS SOCIETY OF PROFESSIONAL SURVEYORS' (TSPS) CATEGORY 6 TOPOGRAPHIC SURVEY AND THAT THIS PROFESSIONAL SERVICE CONFORMS TO RULES OF PROCEDURES AND PRACTICES AS PROMULGATED BY THE TEXAS BOARD OF PROFESSIONAL ENGINEERS AND LAND SURVEYORS.

*(Signature)*



STEVEN RAY ESTES, RPLS  
TEXAS REGISTRATION NO. 5631  
MARCH 25, 2024

PLAT SHOWING TSPS  
CATEGORY 6 TOPOGRAPHIC SURVEY OF

LOT 2 OF WESTERN NATIONAL BANK SUBDIVISION  
A CITED 2.429 ACRE TRACT OF LAND  
SITUATED IN THE  
ZENO PHILLIPS LEAGUE OR SURVEY, ABSTRACT NO. 45  
BRYAN, BRAZOS COUNTY, TEXAS



KCI TECHNOLOGIES, INC.  
1555 GREENS PRAIRIE ROAD WEST  
COLLEGE STATION, TEXAS 77845  
PHONE: 979.846.6212  
KCI.COM  
REGISTRATION: ENG F-2214 & SURVEYING 10042800

DATE: MARCH 25, 2024  
JOB NO. 342210287  
DESIGNED BY:  
DRAWN BY: LC  
CHECKED BY: SRE

SHEET

1

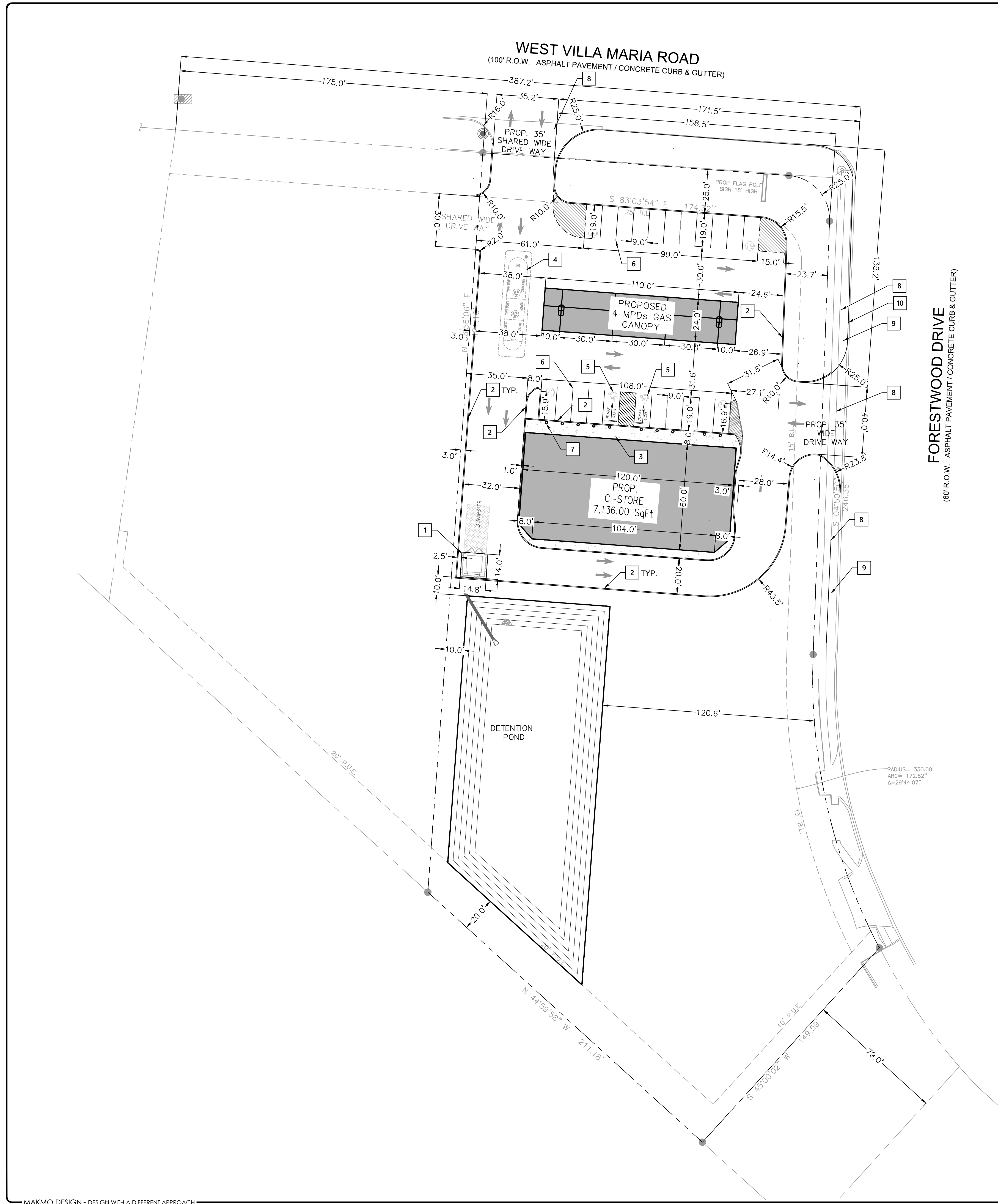

- 1 TRASH ENCLOSURE SEE DETAIL ON SHEET C-6.0.
- 2 6" CONCRETE CURB SEE DETAIL ON SHEET C-6.0.
- 3 CONCRETE SIDEWALK SEE DETAIL ON SHEET C-6.0.
- 4 PROPOSED FUEL TANK BY OTHERS.
- 5 FOR ADA PARKING DETAIL AND SIGN REFER DETAIL ON SHEET C-5.0.
- 6 NEW PAVEMENT MARKING FOR PARKING SPACES
- 7 INSTALL NEW BOLLARDS. SEE DETAIL ON THIS SHEET.
- 8 REMOVE EX CURB
- 9 REMOVE EX DRIVEWAY.
- 10 NEW 6" CONCRETE CURB PER CITY OF BRYAN.

**DIMENSION LAYOUT NOTES**

- THE CONTRACTOR SHALL LAYOUT AND VERIFY ALL DIMENSIONS PRIOR TO CONSTRUCTION. ANY DISCREPANCIES SHALL BE BROUGHT TO THE ATTENTION OF THE ENGINEER FOR DIRECTION AND RESOLUTION OF DISCREPANCIES PRIOR TO PROCEEDING.
- VERIFY LOCATIONS OF ALL SITE IMPROVEMENTS INSTALLED UNDER OTHER SECTIONS. IF ANY PART OF THIS PLAN CANNOT BE FOLLOWED DUE TO SITE CONDITIONS, CONTACT THE ENGINEER FOR INSTRUCTION PRIOR TO COMMENCING WORK.
- WRITTEN DIMENSIONS TAKE PRECEDENCE OVER SCALE.
- WHERE DIMENSIONS ARE CALLED AS "EQUAL", ALL REFERENCED ITEMS SHALL BE SPACED EQUALLY. MEASURED TO THEIR CENTER LINES.
- ALL DIMENSIONS ARE PERPENDICULAR TO FACE OF BUILDING, WALL OR OTHER FIXED SITE IMPROVEMENT AND DIMENSIONS AT CURB ARE FROM BACK OF CURB UNLESS OTHERWISE NOTED.
- INSTALL ALL INTERSECTING ELEMENTS AT 90 DEGREES TO EACH OTHER UNLESS OTHERWISE NOTED.

**EXPANSION JOINTS:**

PROVIDE EXPANSION JOINTS IN ALL CASES WHERE CONCRETE FLATWORK MEETS OTHER STRUCTURES SUCH AS WALLS, CURBS, STEPS & BUILDINGS OR WHERE CONCRETE ABUTS EXISTING CONCRETE PAVING, UTILITY VAULTS, JUNCTION BOXES, ETC. EXPANSION JOINTS REQUIRED AT THESE STRUCTURES MAY NOT BE SHOWN ON THESE DRAWINGS BUT ARE A CONSTRUCTION REQUIREMENT. SEE DETAILS FOR LOCATIONS THAT REQUIRE INSTALLATION OF DOWELS.

**GENERAL NOTES**

- LOCATIONS OF THE EXISTING UTILITIES ARE BASED ON RECORDS FROM SAID UTILITY COMPANIES AND ARE HORIZONTALLY FIELD LOCATED ONLY. THE CONTRACTORS SHALL BE RESPONSIBLE FOR DETERMINING ACTUAL LOCATION.
- CONTRACTOR TO UNCOVER AND MARK UTILITY LINES BEFORE CONSTRUCTION.
- CONTRACTOR SHALL BEAR ALL RESPONSIBILITY AND COST OF REPAIR OR REPLACEMENT OF EXISTING UTILITIES, DAMAGED OR INTERRUPTED AS A RESULT OF THIS CONSTRUCTION PROJECT.
- CONTRACTOR SHALL NOTIFY THE PROJECT ENGINEER AND THE OWNER OF ANY DAMAGED OR INTERRUPTED UTILITIES IMMEDIATELY.
- ALL WATER LINES AND APPURTENANCES SHALL BE INSTALLED IN ACCORDANCE WITH LOCAL WATER STANDARD PIPELINE MATERIALS AND CONSTRUCTION SPECIFICATIONS, LATEST EDITION.
- EXISTING UTILITIES TO REMAIN ARE TO BE ADJUSTED TO MATCH PROPOSED GRADE.
- CONTRACTOR SHALL NOTIFY PROJECT ENGINEER PRIOR TO BEGINNING WORK.
- ALL AREAS WITHIN THE PAVED AREAS ARE TO RECEIVE A GRAVEL BASE TO PROVIDE EROSION CONTROL. IF WORK IS NOT PROGRESSING IN AN ORDERLY MANNER, A RATE OF 135 TONS/ACRE IS TO BE APPLIED WITHIN TWO WEEKS OF FINAL GRADING.
- ALL AREAS NOT WITHIN THE PAVED AREA ARE TO RECEIVE LOOSE STRAW TO PROVIDE EROSION CONTROL. IF WORK IS NOT PROGRESSING IN AN ORDERLY MANNER, A RATE OF 1.5 TONS/ACRE IS TO BE APPLIED WITHIN TWO WEEKS OF FINAL GRADING.
- AFTER NEW INLETS ARE CONSTRUCTED, INSTALL INLET PROTECTION PER DETAIL.
- CONTRACTOR WILL CONTROL AND PREVENT OFF-SITE TRACKING OF CONSTRUCTION RUNOFF AND SEDIMENT TO ADJACENT PROPERTY AND PUBLIC ROADS.
- CONTRACTOR IS TO PROTECT EXISTING STORM DRAINAGE SYSTEM.
- CONTRACTOR TO CONFORM TO ALL CONSTRUCTION STORM WATER AND EROSION CONTROL, PERMITTING REQUIREMENTS BY "EPA PHASE II STORM WATER REGULATIONS" AS ADMINISTERED BY THE TEXAS COMMISSION OF ENVIRONMENTAL QUALITY. WHERE PERMITTING IS REQUIRED, A COPY OF THE NOTICE OF INTENT SHALL BE PROVIDED TO THE LOCAL MUNICIPAL AUTHORITY.
- CONTRACTOR SHALL LOCATE ALL EXISTING UTILITIES IN ACCORDANCE WITH THE TEXAS UNDERGROUND FACILITIES DAMAGE PREVENTION ACT. THIS LAW REQUIRES THAT THE CONTRACTOR MAKE A TELEPHONE CALL TO THE TEXAS ONE-CALL SYSTEM AT 1-800-544-8377 (811) AT LEAST TWO WORKING DAYS PRIOR TO EXCAVATION TO ENSURE THAT ANY EXISTING UTILITIES CAN BE LOCATED.
- CONTRACTOR TO CONSTRUCT ALL ACCESS RAMPS AND PAVING TO ADA STANDARDS. VERIFY.
- TREES TO REMAIN ARE TO BE PROTECTED FROM DAMAGE DURING CONSTRUCTION.
- EXCESS EXPORTS SHALL BE STOCKPILED AT LOCATION APPROVED BY OWNER AND CONFIRMED BY ENGINEER OF RECORD.

SEE ARCHITECTURAL PLANS FOR BUILDING DIMENSIONS

ALL DIMENSIONS ARE TO BACK OF CURB UNLESS NOTED OTHERWISE

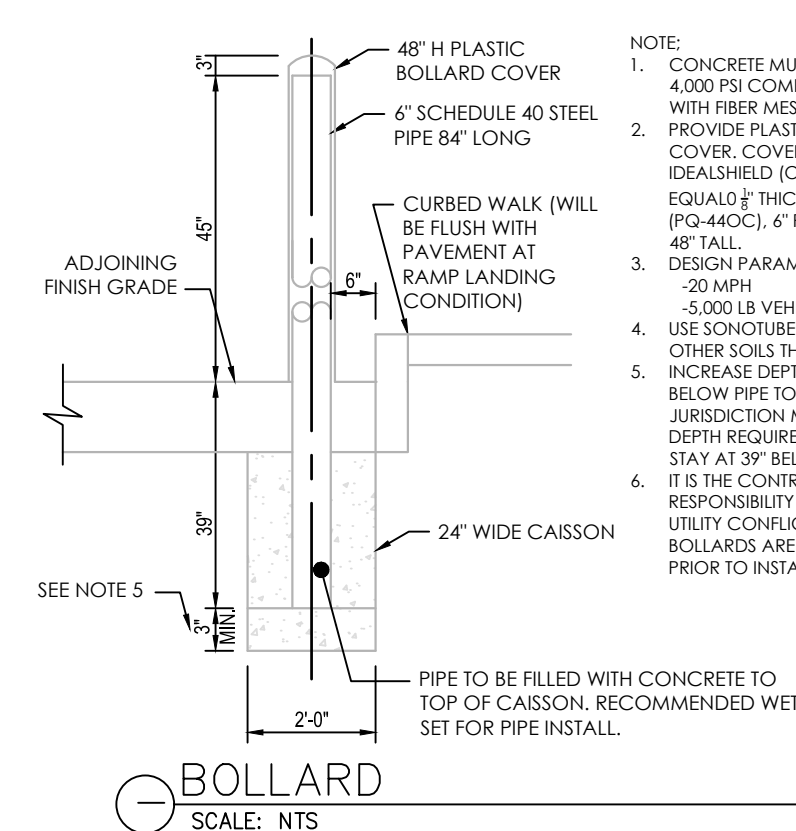

- NOTE:
- CONCRETE MUST BE MINIMUM 4000 PSI COMPRESSIVE STRENGTH WITH FIBER MESH.
  - PROVIDE PLASTIC BOLLARD COVER. COVER TO BE IDEALLY SHIELDED FOR APPROVED EQUAL TO THICK BROWN (PO-440C), 6" PIPE FIT, DOME TOP, 48" TALL.
  - DESIGN PARAMETERS:  
-20 MPH  
-5,000 LB VEHICLE
  - USE SCHEDULE IN SANDY OR OTHER SOILS THAT MIGHT CAVE IN.
  - INCREASE DEPTH OF CAISSON BELOW PIPE TO MEET LOCAL JURISDICTION MINIMUM FROST DEPTH REQUIREMENT. PIPE CAN STAY AT 3" BELOW PAVEMENT.
  - IT IS THE CONTRACTORS RESPONSIBILITY TO VERIFY NO UTILITY CONFLICTS EXIST WHERE BOLLARDS ARE TO BE INSTALLED. PRIOR TO INSTALLATION.

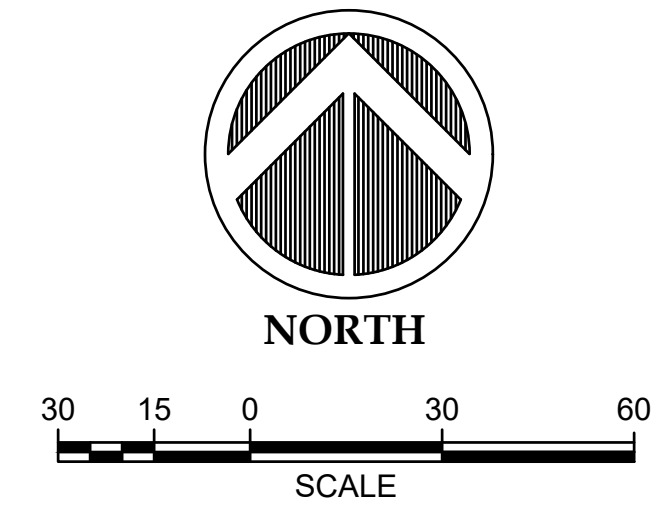

ISSUE FOR:  
FOR INTER REVIEW ONLY  
BID ONLY  
PERMITS SET  
CONSTRUCTION SET

REVISIONS:

NO.	DATE	DESCRIPTION

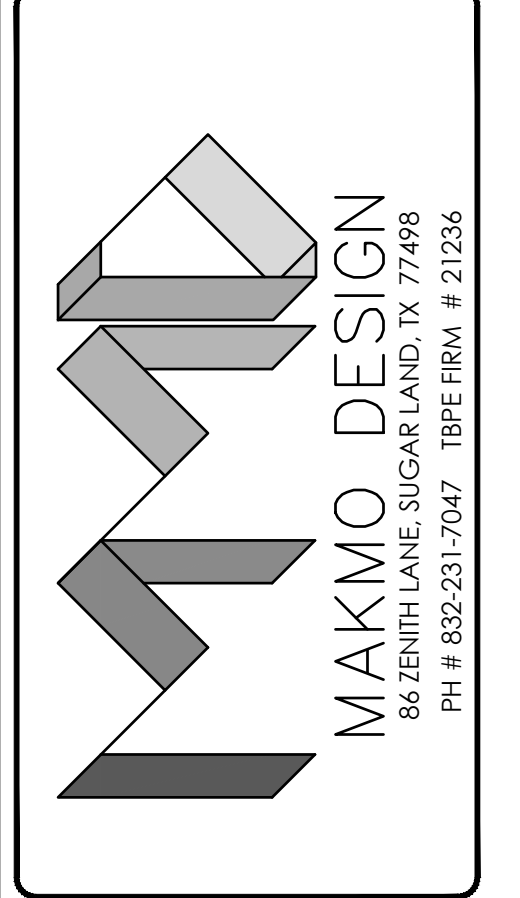

**PROPOSED C STORE & GAS STATION**  
LOCATED AT  
**1001 W VILLA MARIA RD, BRYAN, TX 77801**

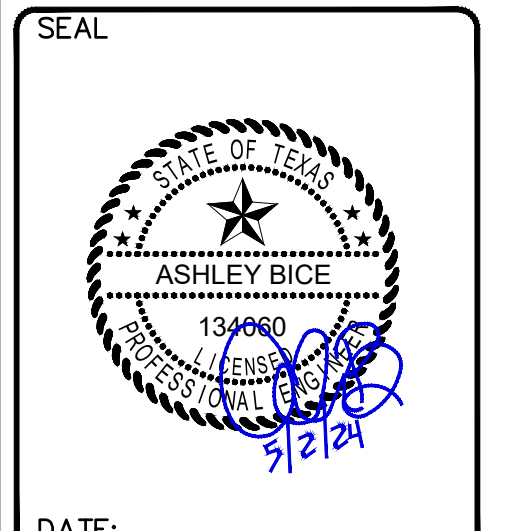

DATE: \_\_\_\_\_





PROJECT NUMBER 23-000  
SCALE 1" = 30'  
DRAWN BY R.R.  
CHECKED BY A.Z.  
SHEET TITLE :

**SITE PLAN**

DRAWING NUMBER:  
**C-1.0**

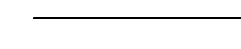
**WEST VILLA MARIA ROAD**  
(100' R.O.W. ASPHALT PAVEMENT / CONCRETE CURB & GUTTER)

**LEGEND**

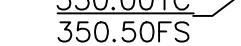
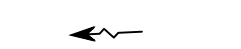
- PROPERTY LINE 
- STORM DRAIN 
- CATCH BASIN 
- EX ELEVATIONS 
- NEW ELEVATIONS 
- SLOPE ARROW 

- GRADING PLAN NOTES**
- THE CONTRACTOR SHALL TAKE ALL PRECAUTIONS NECESSARY TO AVOID PROPERTY DAMAGE TO ADJACENT PROPERTIES DURING THE CONSTRUCTION PHASE OF THE PROJECT. THE CONTRACTOR WILL BE HELD RESPONSIBLE FOR ANY DAMAGES TO ADJACENT PROPERTIES OCCURRING DURING THE CONSTRUCTION PHASE OF THE PROJECT.
  - THE CONTRACTOR WILL BE RESPONSIBLE FOR PROVIDING AND MAINTAINING TRAFFIC CONTROL DEVICES SUCH AS BARRICADES, WARNING SIGNS, DIRECTIONAL SIGNS, FLUORESCENT LIGHTS TO CONTROL THE MOVEMENT OF TRAFFIC WHERE NECESSARY. PLACEMENT OF THESE DEVICES SHALL BE APPROVED BY THE OWNER PRIOR TO PLACEMENT.
  - IN ACCORDANCE WITH GENERALLY ACCEPTED CONSTRUCTION PRACTICES, THE CONTRACTOR WILL BE SOLELY AND COMPLETELY RESPONSIBLE FOR CONDITIONS ON THE JOB SITE, INCLUDING SAFETY OF ALL PERSONS AND PROPERTY DURING THE PERFORMANCE OF THE WORK. THIS REQUIREMENT WILL APPLY CONTINUOUSLY AND NOT BE LIMITED TO NORMAL WORKING HOURS.
  - CONSTRUCTION NEW, INSPECTION, AND OBSERVATION OF THE CONTRACTOR'S PERFORMANCE IS NOT INTENDED AS A REVIEW OF THE ADEQUACY OF THE CONTRACTOR'S SAFETY MEASURES IN, OR NEAR THE CONSTRUCTION SITE.
  - THE CONTRACTOR SHALL BE REQUIRED TO OBTAIN ALL PERMITS FROM AUTHORITIES AND REGULATORY AGENCIES HAVING JURISDICTION OVER THIS SITE, AS REQUIRED, PRIOR TO BEGINNING WORK.
  - BEFORE BEGINNING CONSTRUCTION, THE CONTRACTOR SHALL COMPLY WITH THE EROSION CONTROL PLAN AND/OR PERMIT.
  - THE CONTRACTOR SHALL FIELD VERIFY LOCATIONS AND ELEVATIONS OF EXISTING UTILITIES AND TOPOGRAPHIC FEATURES PRIOR TO COMMENCEMENT OF CONSTRUCTION ACTIVITY. THE CONTRACTOR SHALL NOTIFY THE ENGINEER OF ANY DISCREPANCIES OR VARIATIONS FROM THE PLANS.
  - TRAFFIC MINIMIZE INTERFERENCE WITH ADJOINING ROADS, STREETS, WALKS, AND OTHER ADJACENT OCCUPIED OR USED FACILITIES DURING EARTH MOVING OPERATIONS.
    - DO NOT CLOSE OR OBSTRUCT STREETS, WALKS, OR OTHER ADJACENT OCCUPIED OR USED FACILITIES WITHOUT PERMISSION FROM OWNER AND AUTHORITIES HAVING JURISDICTION.
    - PROVIDE ALTERNATE ROUTES AROUND CLOSED OR OBSTRUCTED TRAFFIC WAYS IF REQUIRED BY OWNER OR AUTHORITIES HAVING JURISDICTION.
  - DO NOT CONDUCT WORK ON ADJOINING PROPERTY UNLESS DIRECTED BY ENGINEER.
  - DO NOT COMMENCE EARTH-MOVING OPERATIONS UNTIL TEMPORARY EROSION- AND SEDIMENTATION-CONTROL MEASURES ARE IN PLACE.
  - INSTALL DETECTABLE WARNING TAPE ABOVE CONSTRUCTED UTILITIES. DETECTABLE WARNING TAPE IS DEFINED AS: ACID- AND ALKALI-RESISTANT, POLYETHYLENE FILM WARNING TAPE MANUFACTURED FOR MARKING AND IDENTIFYING UNDERGROUND UTILITIES. A MINIMUM OF 6 INCHES WIDE AND 4 MILS THICK, CONTINUOUSLY INSCRIBED WITH A DESCRIPTION OF THE UTILITY, WITH METALLIC CORE ENCASED IN A PROTECTIVE JACKET FOR CORROSION PROTECTION, DETECTABLE BY METAL DETECTOR WHEN TAPE IS BURIED UP TO 30 INCHES DEEP. COLORED AS FOLLOWS:
    - RED: ELECTRIC.
    - YELLOW: GAS, OIL, STEAM, AND DANGEROUS MATERIALS.
    - ORANGE: TELEPHONE AND OTHER COMMUNICATIONS
    - BLUE: WATER SYSTEMS.
    - GREEN: SEWER SYSTEMS.
  - PROTECT STRUCTURES, UTILITIES, SIDEWALKS, PAVEMENTS, AND OTHER FACILITIES FROM DAMAGE CAUSED BY SETTLEMENT, LATERAL MOVEMENT, UNDERMINING, WASHOUT, AND OTHER HAZARDS CREATED BY EARTH MOVING OPERATIONS.
  - PROTECT AND MAINTAIN EROSION AND SEDIMENTATION CONTROLS DURING EARTH MOVING OPERATIONS.
  - PROTECT SUBGRADES AND FOUNDATION SOILS FROM FREEZING TEMPERATURES AND FROST. REMOVE TEMPORARY PROTECTION BEFORE PLACING SUBSEQUENT MATERIALS.
  - IF EXCAVATED MATERIALS INTENDED FOR FILL AND BACKFILL INCLUDE UNSATISFACTORY SOIL MATERIALS AND ROCK, REPLACE WITH SATISFACTORY SOIL MATERIALS.
  - EXCAVATE TO INDICATED ELEVATIONS AND DIMENSIONS WITHIN A TOLERANCE OF PLUS OR MINUS 1 INCH. IF APPLICABLE, EXTEND EXCAVATIONS A SUFFICIENT DISTANCE FROM STRUCTURES FOR PLACING AND REMOVING CONCRETE FORMWORK, FOR INSTALLING SERVICES AND OTHER CONSTRUCTION, AND FOR INSPECTIONS.
    - EXCAVATIONS FOR FOOTINGS AND FOUNDATIONS: DO NOT DISTURB BOTTOM OF EXCAVATION. EXCAVATE BY HAND TO FINAL GRADE JUST BEFORE PLACING CONCRETE REINFORCEMENT. TRIM BOTTOMS TO REQUIRED LINES AND GRADES TO LEAVE SOLID BASE TO RECEIVE OTHER WORK.
    - EXCAVATION FOR UNDERGROUND TANKS, BASINS, AND MECHANICAL OR ELECTRICAL UTILITY STRUCTURES: EXCAVATE TO ELEVATIONS AND DIMENSIONS INDICATED WITHIN A TOLERANCE OF PLUS OR MINUS 1 INCH. DO NOT DISTURB BOTTOM OF EXCAVATIONS INTENDED AS BEARING SURFACES.
  - EXCAVATIONS AT EDGES OF TREE- AND PLANT-PROTECTION ZONES:
    - EXCAVATE BY HAND TO INDICATED LINES, CROSS SECTIONS, ELEVATIONS, AND SUBGRADES. USE NARROW-TINE SPADING FORKS TO COMB SOIL, AND EXPOSE ROOTS. DO NOT BREAK, TEAR, OR CHOP EXPOSED ROOTS. DO NOT USE MECHANICAL EQUIPMENT THAT RIPS, TEARS, OR PULLS ROOTS.
  - GENERAL: UNIFORMLY GRADE AREAS TO A SMOOTH SURFACE, FREE OF IRREGULAR SURFACE CHANGES. COMPLY WITH COMPACTION REQUIREMENTS AND GRADE TO CROSS SECTIONS, LINES, AND ELEVATIONS INDICATED.
    - PROVIDE A SMOOTH TRANSITION BETWEEN ADJACENT EXISTING GRADES AND NEW GRADES.
    - CUT OUT SOFT SPOTS, FILL LOW SPOTS, AND TRIM HIGH SPOTS TO COMPLY WITH REQUIRED SURFACE TOLERANCES.
  - SITE ROUGH GRADING: SLOPE GRADES TO DIRECT WATER AWAY FROM BUILDINGS AND TO PREVENT PONDING.

**ROOF DRAIN NOTE:**  
CONTRACTOR TO CONNECT ALL DOWNSPOUTS TO THE NEAREST UNDERGROUND STORM SEWER  
CONTRACTOR TO PROVIDED CONCRETE SPLASH BLOCK FOR EACH ROOF DRAIN NOT CONNECTED DIRECTLY TO STORM SEWER PIPING.



**FLOODPLAIN INFORMATION:**  
According to the Federal Emergency Management Agency (FEMA) Flood Insurance Rate Map (FIRM) Map No. 48041C0215F, with the effective date of OCTOBER 16, 2014, the property is located in Flood Zone "X". Areas determined to be outside of the regulated floodway. All Floodplain information noted in the plat reflects the status per the FEMA FIRM map that is effective at the time that the plat is recorded. Floodplain and Floodway status is subject to change as FEMA FIRM maps are updated.

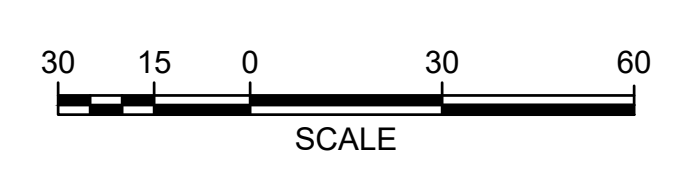
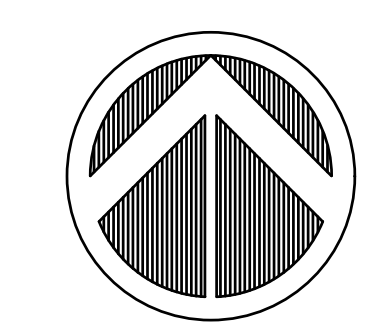

ISSUE FOR:  
FOR INTER REVIEW ONLY   
BID ONLY   
PERMITS SET   
CONSTRUCTION SET

**REVISIONS:**

NO.	DATE	DESCRIPTION

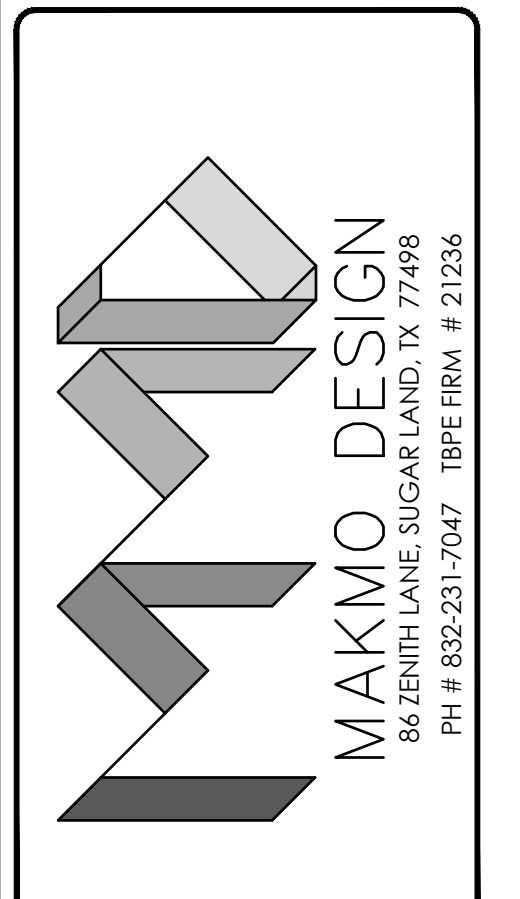

**PROPOSED C STORE & GAS STATION**  
LOCATED AT  
**1001 W VILLA MARIA RD, BRYAN, TX 77801**

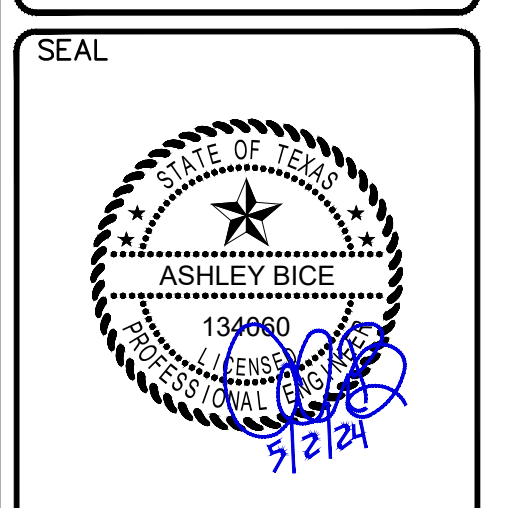

DATE: \_\_\_\_\_

PROJECT NUMBER: 23-000  
SCALE: 1" = 30'  
DRAWN BY: R.R.  
CHECKED BY: A.Z.  
SHEET TITLE: \_\_\_\_\_

**GRADING PLAN**

DRAWING NUMBER:  
**C-2.0**

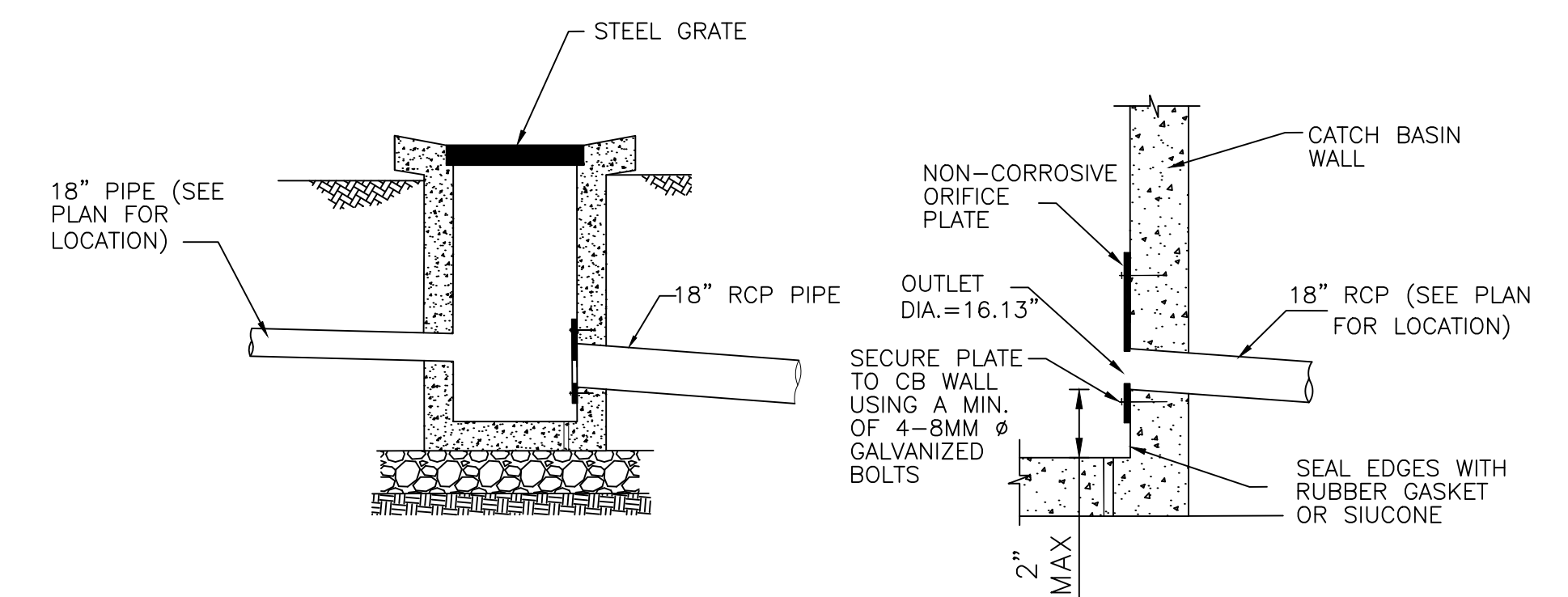
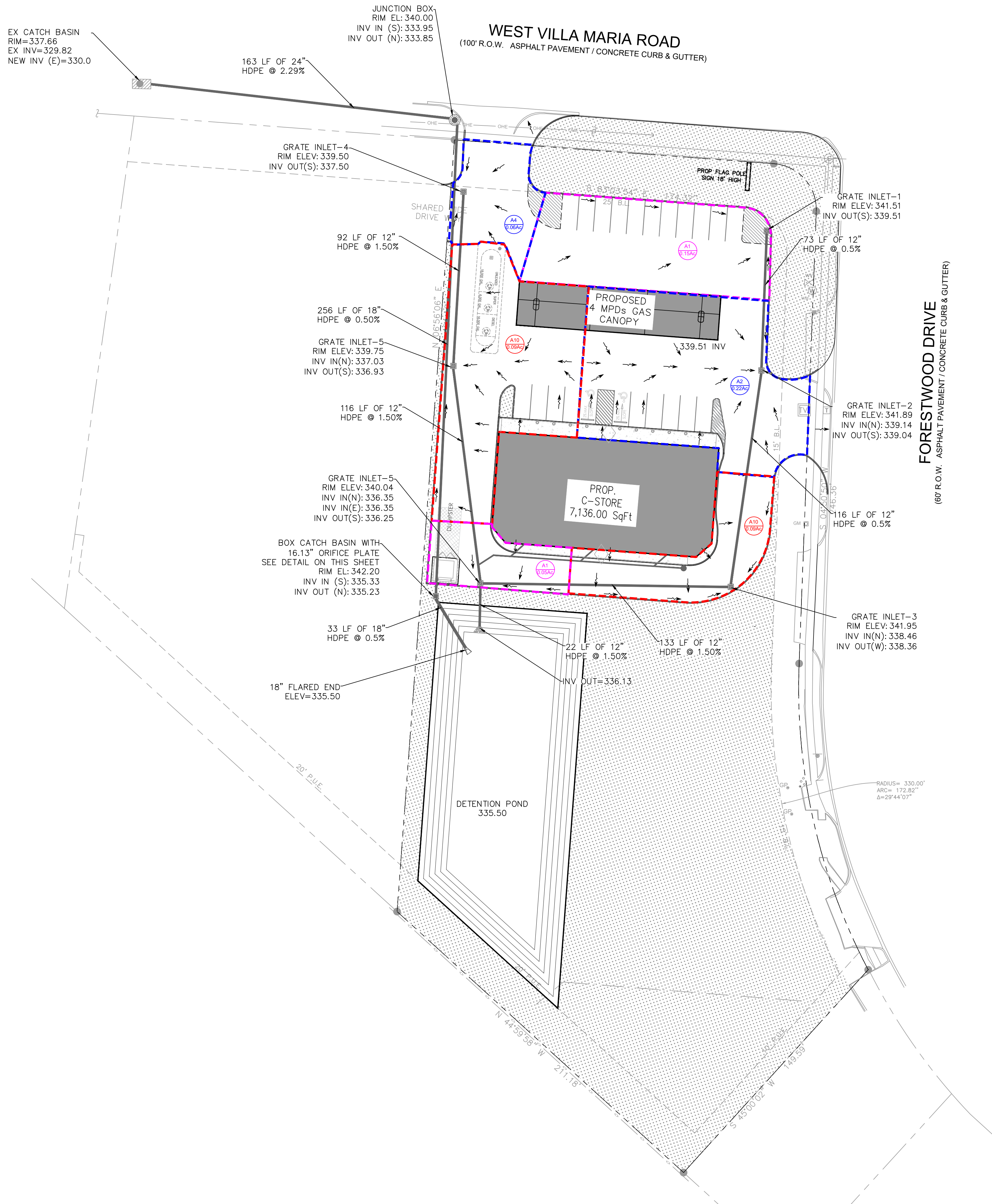

ORIFICE CONTROL CATCH BASIN DETAIL

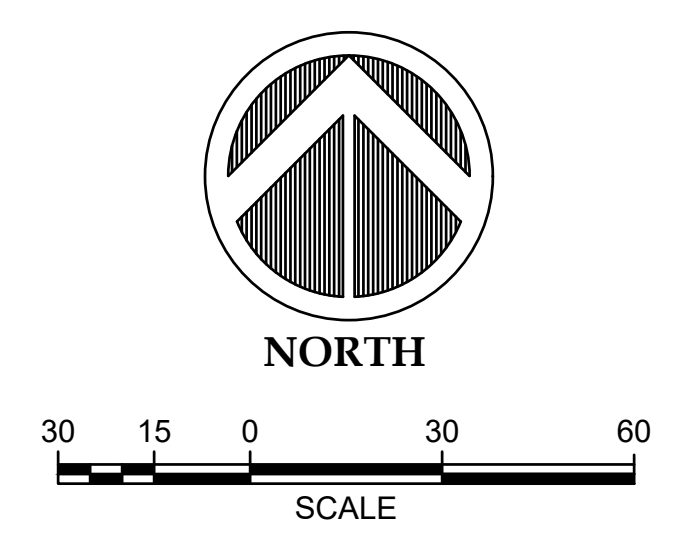

ISSUE FOR:  
 FOR INTER REVIEW ONLY   
 BID ONLY   
 PERMITS SET   
 CONSTRUCTION SET

REVISIONS:

NO.	DATE	DESCRIPTION

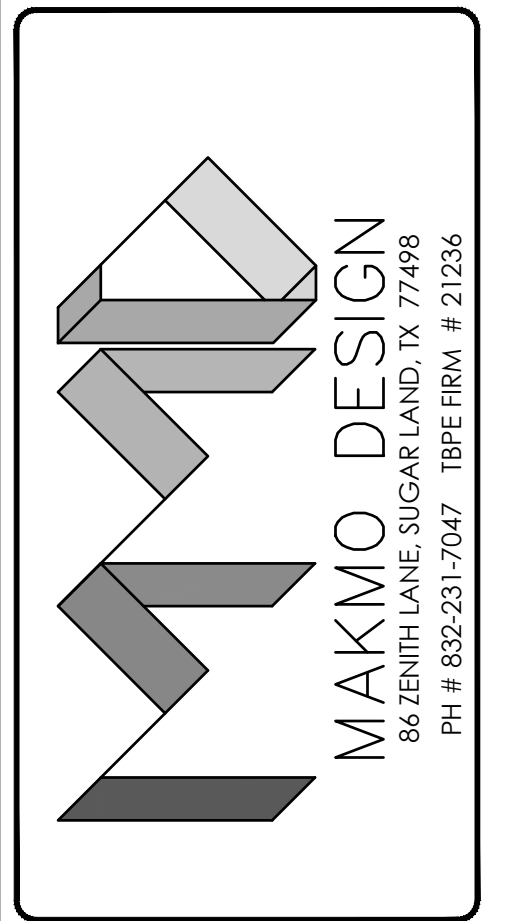

**PROPOSED C STORE & GAS STATION**  
 LOCATED AT  
**1001 W VILLA MARIA RD, BRYAN, TX 77801**

SEAL

DATE:

PROJECT NUMBER 23-000  
 SCALE 1" = 30'  
 DRAWN BY R.R  
 CHECKED BY A.Z  
 SHEET TITLE :

**DRAINAGE PLAN**

DRAWING NUMBER:  
**C-2.1**



ISSUE FOR:  
 FOR INTER REVIEW ONLY   
 BID ONLY   
 PERMITS SET   
 CONSTRUCTION SET

REVISIONS:		
NO.	DATE	DESCRIPTION

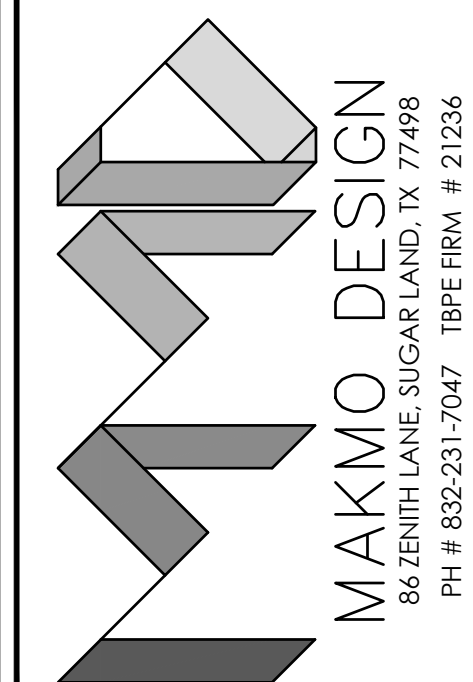

**PROPOSED C STORE & GAS STATION**  
 LOCATED AT  
**1001 W VILLA MARIA RD, BRYAN, TX 77801**

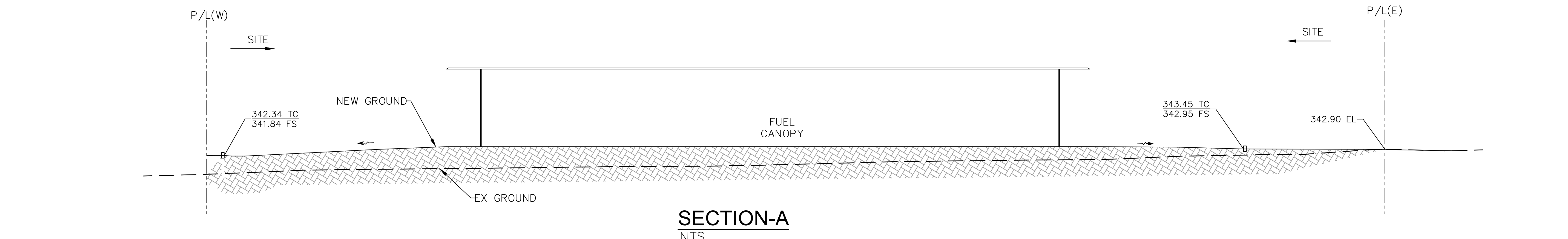

**SECTION-A**  
NTS

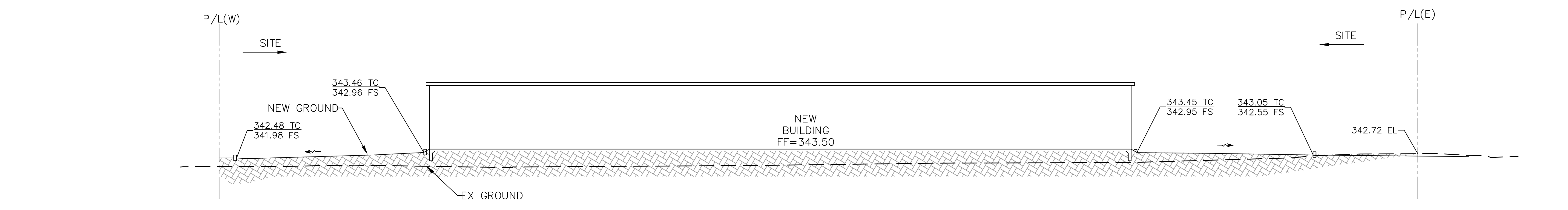

**SECTION-B**  
NTS

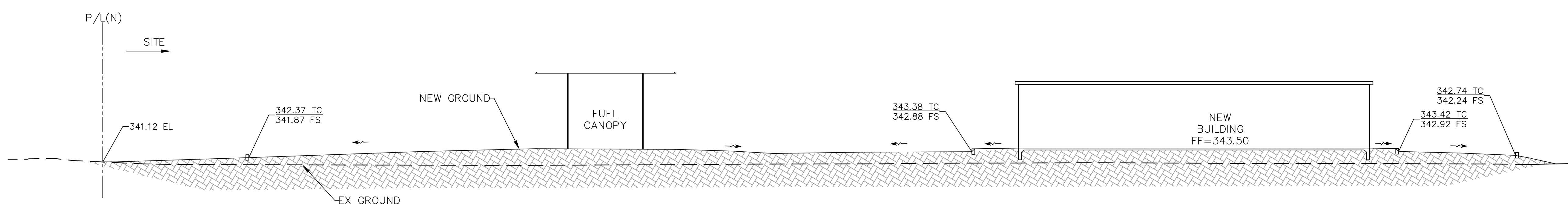

**SECTION-C**  
NTS

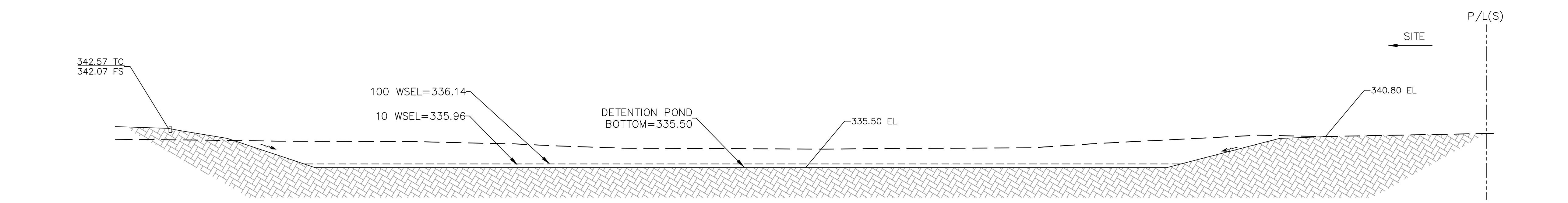

**SECTION-D**  
NTS

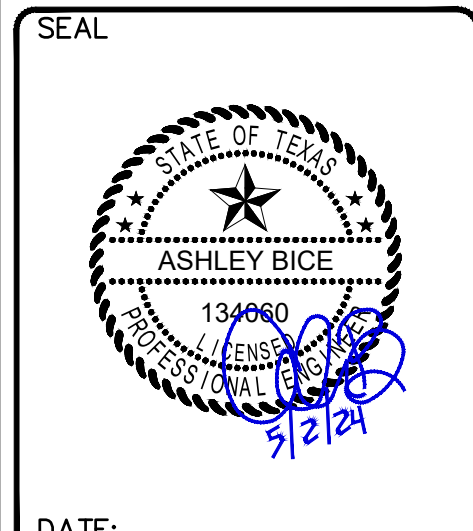

DATE:

PROJECT NUMBER	23-000
SCALE	
DRAWN BY	R.R
CHECKED BY	A.Z
SHEET TITLE	

**SITE SECTIONS**

DRAWING NUMBER:  
**C-2.3**

**WEST VILLA MARIA ROAD**  
(100' R.O.W. ASPHALT PAVEMENT / CONCRETE CURB & GUTTER)

**FORESTWOOD DRIVE**  
(60' R.O.W. ASPHALT PAVEMENT / CONCRETE CURB & GUTTER)

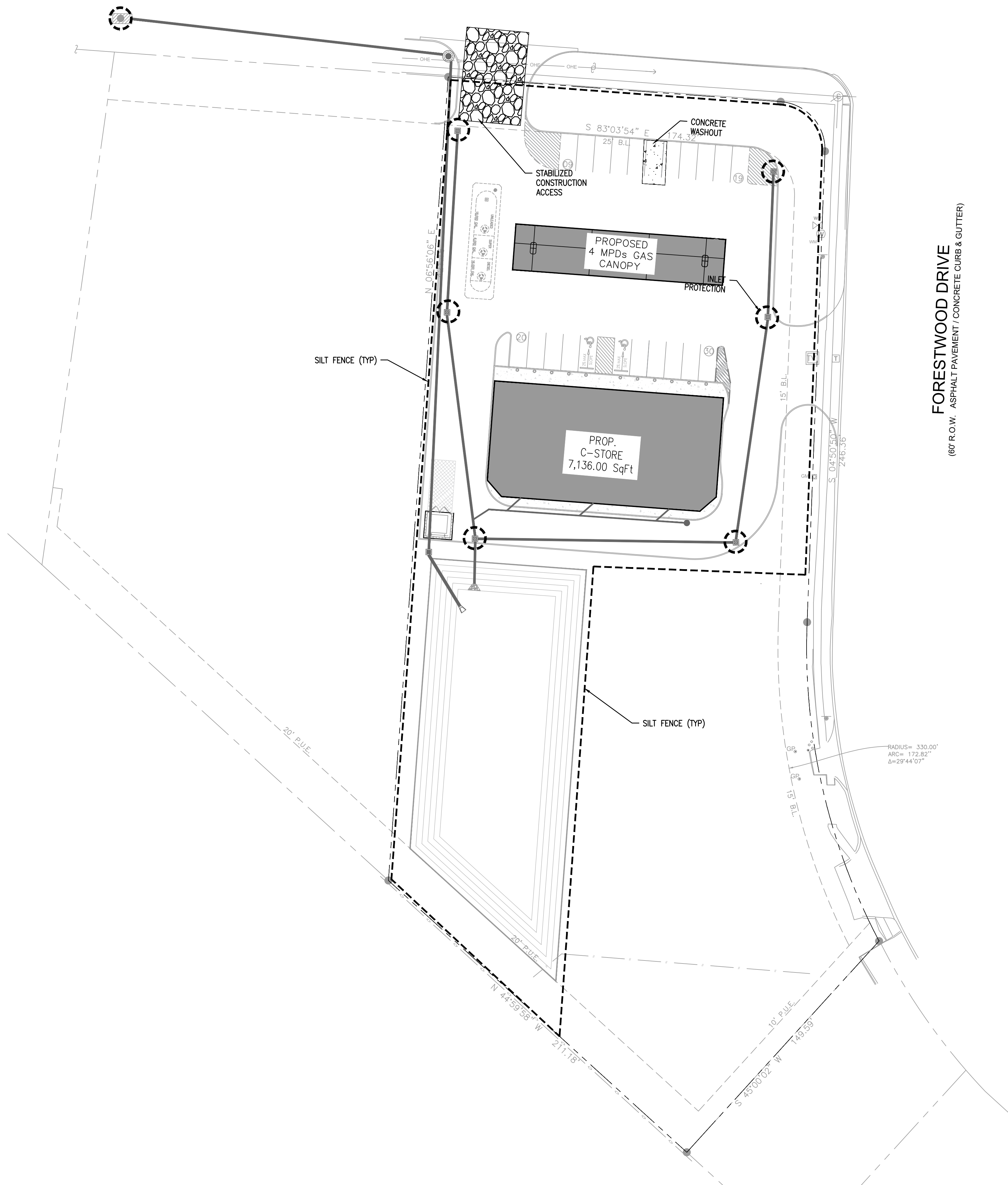

- GENERAL NOTES**
- LOCATIONS OF THE EXISTING UTILITIES ARE BASED ON RECORDS FROM SAID UTILITY COMPANIES AND ARE HORIZONTALLY FIELD LOCATED ONLY. THE CONTRACTORS SHALL BE RESPONSIBLE FOR DETERMINING ACTUAL LOCATION.
  - CONTRACTOR TO UNCOVER AND MARK UTILITY LINES BEFORE CONSTRUCTION.
  - CONTRACTOR SHALL BEAR ALL RESPONSIBILITY AND COST OF REPAIR OR REPLACEMENT OF EXISTING UTILITIES, DAMAGED OR INTERRUPTED AS A RESULT OF THIS CONSTRUCTION PROJECT.
  - CONTRACTOR SHALL NOTIFY THE PROJECT ENGINEER AND THE OWNER OF ANY DAMAGED OR INTERRUPTED UTILITIES IMMEDIATELY.
  - ALL WATER LINES AND APPURTENANCES SHALL BE INSTALLED IN ACCORDANCE WITH LOCAL WATER STANDARD PIPELINE MATERIALS AND CONSTRUCTION SPECIFICATIONS, LATEST EDITION.
  - EXISTING UTILITIES TO REMAIN ARE TO BE ADJUSTED TO MATCH PROPOSED GRADE.
  - CONTRACTOR SHALL NOTIFY PROJECT ENGINEER PRIOR TO BEGINNING WORK.
  - ALL AREAS WITHIN THE PAVED AREAS ARE TO RECEIVE A GRAVEL BASE TO PROVIDE EROSION CONTROL. IF WORK IS NOT PROGRESSING IN AN ORDERLY MANNER, A RATE OF 135 TONS/ACRE IS TO BE APPLIED WITHIN TWO WEEKS OF FINAL GRADING.
  - ALL AREAS NOT WITHIN THE PAVED AREA ARE TO RECEIVE LOOSE STRAW TO PROVIDE EROSION CONTROL. IF WORK IS NOT PROGRESSING IN AN ORDERLY MANNER, A RATE OF 1.5 TONS/ACRE IS TO BE APPLIED WITHIN TWO WEEKS OF FINAL GRADING.
  - AFTER NEW INLETS ARE CONSTRUCTED, INSTALL INLET PROTECTION PER DETAIL.
  - CONTRACTOR WILL CONTROL AND PREVENT OFF-SITE TRACKING OF CONSTRUCTION RUNOFF AND SEDIMENT TO ADJACENT PROPERTY AND PUBLIC ROADS.
  - CONTRACTOR IS TO PROTECT EXISTING STORM DRAINAGE SYSTEM.
  - CONTRACTOR TO CONFORM TO ALL CONSTRUCTION STORM WATER AND EROSION CONTROL PERMITTING REQUIREMENTS BY "EPA PHASE II STORM WATER REGULATIONS" AS ADMINISTERED BY THE TEXAS COMMISSION OF ENVIRONMENTAL QUALITY. WHERE PERMITTING IS REQUIRED, A COPY OF THE NOTICE OF INTENT AND CONSTRUCTION SITE NOTICE(S) SHALL BE PROVIDED TO THE LOCAL MUNICIPAL AUTHORITY. CONTRACTOR SHALL POST THE CONSTRUCTION SITE NOTICE(S) IN ACCORDANCE WITH THE TEXAS COMMISSION ON ENVIRONMENTAL QUALITY REQUIREMENTS.
  - CONTRACTOR SHALL LOCATE ALL EXISTING UTILITIES IN ACCORDANCE WITH THE TEXAS UNDERGROUND FACILITIES DAMAGE PREVENTION ACT. THIS LAW REQUIRES THAT THE CONTRACTOR MAKE A TELEPHONE CALL TO THE TEXAS ONE-CALL SYSTEM AT 1-800-344-6377 (811) AT LEAST TWO WORKING DAYS PRIOR TO EXCAVATION TO ENSURE THAT ANY EXISTING UTILITIES CAN BE LOCATED.
  - CONTRACTOR TO CONSTRUCT ALL ACCESS RAMPS AND PAVING TO ADA STANDARDS. VERIFY.
  - TREES TO REMAIN ARE TO BE PROTECTED FROM DAMAGE DURING CONSTRUCTION.
  - EXCESS EXPORTS SHALL BE STOCKPILED AT LOCATION APPROVED BY OWNER AND CONFIRMED BY ENGINEER OF RECORD.

**EROSION CONTROL LEGEND**

	STABILIZED CONSTRUCTION ENTRANCE
	INLET PROTECTION BARRIER (STAGE I & STAGE II)
	RIPRAP OUTLET PROTECTION
	SILT FENCE (MIN. 2' FROM BOC)
	CONCRETE WASHOUT TRUCK
	SURFACE FLOW

- EROSION CONTROL NOTES**
- ALL DISTURBED UNPAVED AREAS ARE TO RECEIVE A MINIMUM OF 4-INCHES OF TOPSOIL AND 2-INCHES OF COMPOST (FOR A TOTAL OF 6-INCHES) AND SOO OR SEED (AS INDICATED). THESE AREAS SHALL BE WATERED BY THE CONTRACTOR UNTIL THE SOO OR SEED IS GROWING IN A HEALTHY MANNER. SEE LANDSCAPE PLANS FOR MORE REQUIREMENTS.
  - THE CONTRACTOR SHALL TAKE ALL PRECAUTIONS NECESSARY TO AVOID PROPERTY DAMAGE TO ADJACENT PROPERTIES DURING THE CONSTRUCTION PHASE OF THE PROJECT. THE CONTRACTOR WILL BE HELD RESPONSIBLE FOR ANY DAMAGES TO ADJACENT PROPERTIES OCCURRING DURING THE CONSTRUCTION PHASE OF THE PROJECT.
  - THE CONTRACTOR WILL BE RESPONSIBLE FOR MAINTAINING TRAFFIC CONTROL DEVICES SUCH AS BARRICADES, WARNING SIGNS, DIRECTIONAL SIGNS, FLAGMEN AND LIGHTS TO CONTROL THE MOVEMENT OF TRAFFIC WHERE NECESSARY. THESE DEVICES AND THEIR PLACEMENT SHALL BE APPROVED BY THE OWNER PRIOR TO PLACEMENT.
  - IN ACCORDANCE WITH GENERALLY ACCEPTED CONSTRUCTION PRACTICES, THE CONTRACTOR WILL BE SOLELY AND COMPLETELY RESPONSIBLE FOR CONDITIONS ON THE JOB SITE, INCLUDING SAFETY OF ALL PERSONS AND PROPERTY DURING THE PERFORMANCE OF THE WORK. THIS REQUIREMENT WILL APPLY CONTINUOUSLY AND NOT BE LIMITED TO NORMAL WORKING HOURS.
  - THE DUTY OF THE OWNER (OR OWNERS REPRESENTATIVE) TO CONDUCT CONSTRUCTION REVIEW OF THE CONTRACTOR'S PERFORMANCE IS NOT INTENDED TO INCLUDE REVIEW OF THE ADEQUACY OF THE CONTRACTOR'S SAFETY MEASURES IN, OR NEAR THE CONSTRUCTION SITE.
  - BEFORE BEGINNING CONSTRUCTION, THE CONTRACTOR SHALL INSTALL A TEMPORARY ROCK ENTRANCE PAD AT ALL POINTS OF VEHICLE EXIT FROM THE SITE. SAID ROCK ENTRANCE PADS SHALL BE MAINTAINED BY THE CONTRACTOR FOR THE DURATION OF THE PROJECT.
  - EROSION AND SEDIMENTATION CONTROL MEASURES SHALL BE ESTABLISHED AROUND THE ENTIRE SITE PERIMETER AND IN ACCORDANCE WITH BEST MANAGEMENT PRACTICES AND THE PROJECT DETAILS.
  - EROSION CONTROL MEASURES SHALL BE IMMEDIATELY ESTABLISHED UPON COMPLETION OF CLEARING AND GRUBBING.
  - THE INTENDED SEQUENCE OF MAJOR CONSTRUCTION ACTIVITIES IS AS FOLLOWS:
    - INSTALL SILT FENCE AROUND THE PERIMETER OF THE SITE, AND THE ROCK CONSTRUCTION ENTRANCE(S).
    - INSTALL SILT FENCE AND INLET PROTECTION AROUND, AND WITHIN, ALL STRUCTURES.
    - CLEAR AND GRUB.
    - SURFACE FEATURE REMOVALS.
    - ROUGH GRADING OF THE SITE.
    - STABILIZE DENuded AREAS AND STOCKPILES.
    - FINE GRADING OF THE SITE.
    - INSTALL TOPSOIL, COMPOST AND SEED.
    - REMOVE ACCUMULATED SEDIMENT FROM STRUCTURES.
    - WHEN ALL CONSTRUCTION ACTIVITIES ARE COMPLETE AND THE SITE IS STABILIZED, REMOVE SILT FENCE AND RESEED ANY AREAS DISTURBED BY THE REMOVAL WITHIN 30-DAYS OF FINAL STABILIZATION.
  - THE LOCATION OF THE AREAS NOT TO BE DISTURBED MUST BE IDENTIFIED WITH FLAGS, STAKES, SIGNS, SILT FENCE, ETC. BEFORE CONSTRUCTION BEGINS.
  - ALL STORM DRAINS AND INLETS MUST BE PROTECTED UNTIL ALL SOURCES OF POTENTIAL DISCHARGE ARE STABILIZED.
  - SOLID WASTE MUST BE DISPOSED OF PROPERLY AND COMPLY WITH THE GOVERNING AGENCY'S DISPOSAL REQUIREMENTS.
  - EXTERNAL WASHING OF CONSTRUCTION VEHICLES MUST BE LIMITED TO A DEFINED AREA OF THE SITE. THE AREA MUST BE IN A CONTAINED LOCATION WITH A LINER, WASHOUT TO BE REMOVE AND PROPERLY DISPOSED OF FOLLOWING ALL APPLICABLE REGULATIONS. UNDER NO CIRCUMSTANCES SHALL EQUIPMENT BE ALLOWED TO WASH OFF FRESH CONCRETE IN THE STREET OR IN ANY AREA WHERE THE WASHOUT MATERIAL WILL ENTER A WETLAND OR DRAINAGEWAY. CONCRETE WASHOUT WATER SHALL NOT BE DISCHARGED INTO WATERSTORM SYSTEMS.
  - NO ENGINE DEGREASING IS ALLOWED ON SITE.
  - SILT FENCE REQUIRED MAINTENANCE SHALL BE AS FOLLOWS: "WHEN SEDIMENT REACHES TO THE HEIGHT OF THE SILT FENCE FABRIC, THE SEDIMENT MUST BE REMOVED WITHIN 24-HOURS. "REPAIR OR REPLACE DYSFUNCTIONAL SILT FENCE WITHIN 24-HOURS."
  - THE CONTRACTOR SHALL BE REQUIRED TO OBTAIN ALL PERMITS FROM AUTHORITIES AND REGULATORY AGENCIES HAVING JURISDICTION OVER THIS SITE, AS REQUIRED, PRIOR TO BEGINNING WORK.
  - AFTER CONSTRUCTION BEGINS, SOIL SURFACE STABILIZATION SHALL BE APPLIED WITHIN 7-DAYS TO ALL DISTURBED AREAS THAT MAY NOT BE AT FINAL GRADE, BUT WILL REMAIN UNDISTURBED FOR PERIODS LONGER THAN AN ADDITIONAL 21 CALENDAR DAYS.
  - WITHIN 7-DAYS AFTER FINAL GRADE IS REACHED ON ANY PORTION OF THE SITE, PERMANENT OR TEMPORARY SOIL SURFACE STABILIZATION SHALL BE APPLIED TO DISTURBED AREAS AND SOIL STOCKPILES.
  - ALL DISTURBED GROUND LEFT INACTIVE FOR 7 DAYS OR MORE MUST BE STABILIZED BY SEEDING, SODDING OR MULCHING. TYPE OF SLOPE DAYS TO STABILIZE STEEPER THAN 3:1 7 DAYS 10:1 TO 3:1 7 DAYS FLATTER THAN 10:1 7 DAYS.
  - WHEN STABILIZATION MEASURES ARE STOPPED DUE TO SNOW COVER OR ARID CONDITIONS, STABILIZATION MEASURES SHALL BE INITIATED AS SOON AS POSSIBLE. SOIL STABILIZATION MEASURES SHALL INCLUDE, BUT ARE NOT LIMITED TO SURFACE ROUGHENING, TEMPORARY OR PERMANENT VEGETATION, MULCHING, SODDING, LANDSCAPING AND EROSION CONTROL BLANKETS.
  - STABILIZATION MEASURES TO BE USED SHALL BE APPROPRIATE FOR THE TIME OF YEAR, SITE CONDITIONS AND ESTIMATED DURATION OF USE.
  - EXISTING TURF OUTSIDE OF THE CONSTRUCTION LIMITS SHALL NOT BE DISTURBED. ANY TURF SHALL BE RE-ESTABLISHED.
  - ALL STREETS AND PARKING LOTS ADJACENT TO THE SITE SHALL BE CLEANED AND/OR SWEEPED AT THE END OF EACH WORKING DAY.
  - WHEN STABILIZATION MEASURES ARE STOPPED DUE TO SNOW COVER, STABILIZATION MEASURES SHALL BE RE-INITIATED AS SOON AS POSSIBLE. STABILIZATION MEASURES SHALL INCLUDE, BUT ARE NOT LIMITED TO TEMPORARY OR PERMANENT VEGETATION, MULCHING, SODDING, LANDSCAPING AND EROSION CONTROL BLANKETS.
  - TEMPORARY AND PERMANENT EROSION AND SEDIMENT CONTROL PRACTICES SHALL BE MAINTAINED AND REPAIRED BY THE CONTRACTOR DURING THE CONSTRUCTION PHASE AS NEEDED TO ASSURE CONTINUED PERFORMANCE OF THEIR INTENDED FUNCTION.
  - EROSION CONTROL MEASURES SHALL BE MAINTAINED AND REMAIN IN PLACE UNTIL PERMANENT REVEGETATION IS ESTABLISHED.
  - CONTRACTOR TO LOCATE A CONCRETE WASHOUT AREA ON THE PROJECT SITE PRIOR TO BEGINNING WORK.

ISSUE FOR:  
FOR INTER REVIEW ONLY  
BID ONLY  
PERMITS SET  
CONSTRUCTION SET

**REVISIONS:**

NO.	DATE	DESCRIPTION

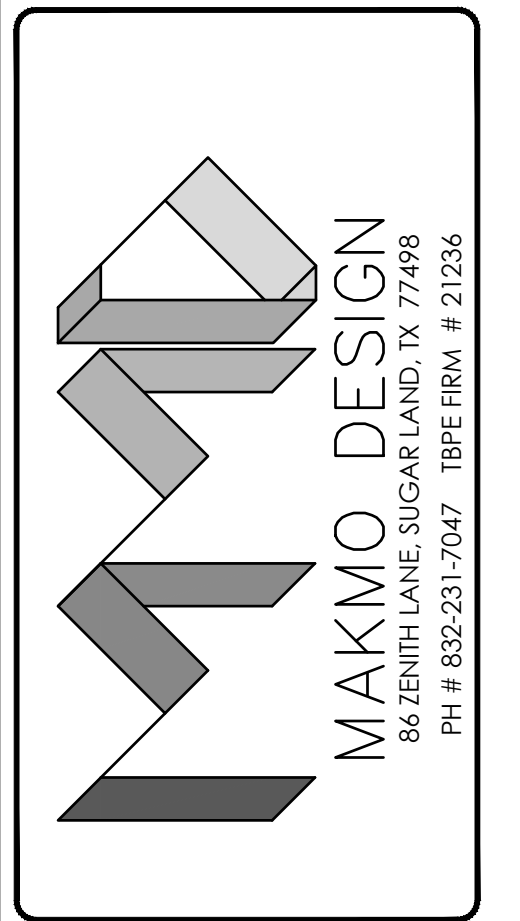

**PROPOSED C STORE & GAS STATION**  
LOCATED AT  
**1001 W VILLA MARIA RD, BRYAN, TX 77801**



SEAL :  
  
DATE: 3/29/2024

PROJECT NUMBER 23-000  
SCALE 1" = 30'  
DRAWN BY R.R  
CHECKED BY A.Z  
SHEET TITLE :



**ESC PLAN**  
  
DRAWING NUMBER:  
**C-3.0**



**WEST VILLA MARIA ROAD**  
(100' R.O.W. ASPHALT PAVEMENT / CONCRETE CURB & GUTTER)

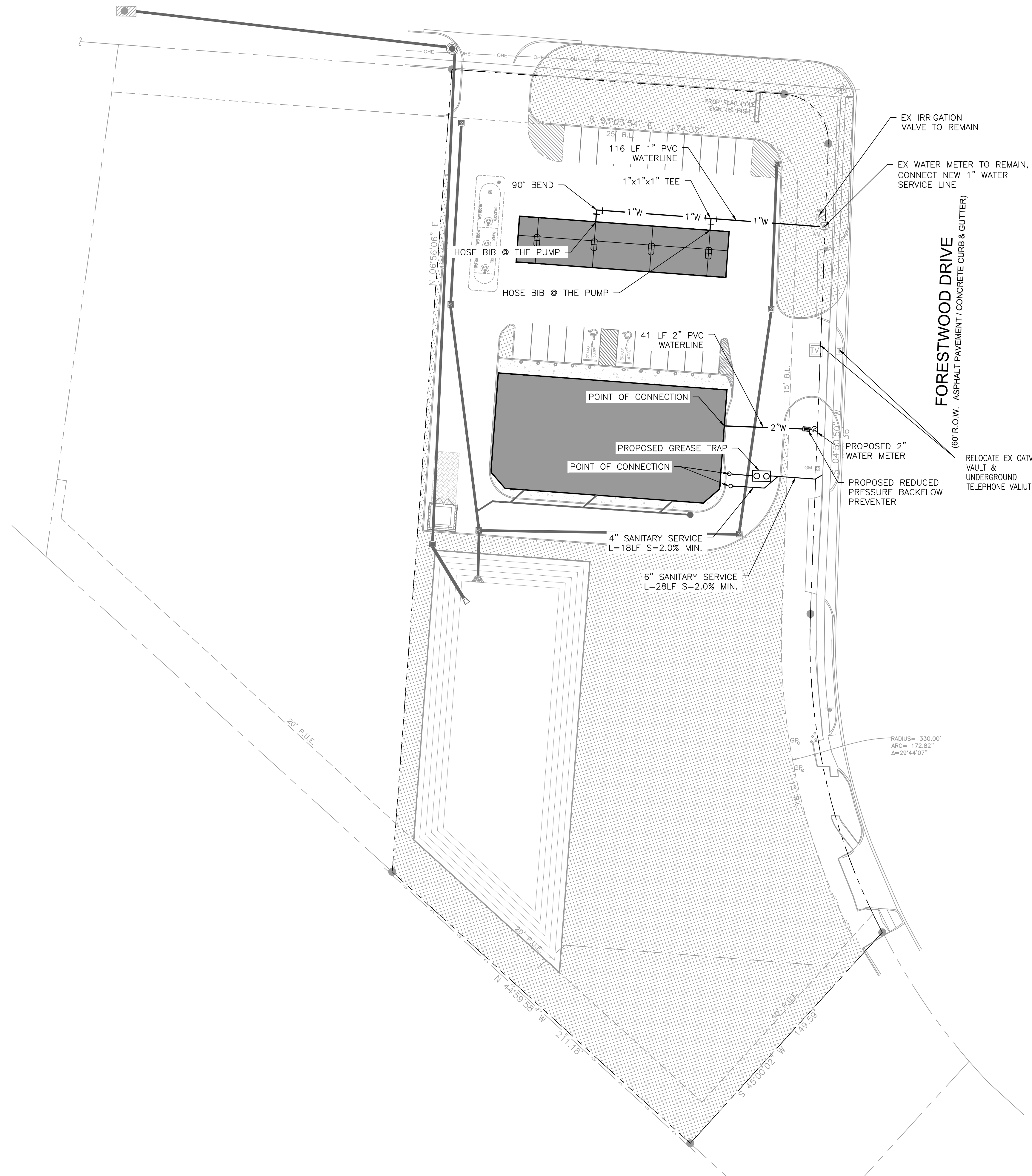

- SEWER NOTES:**
- SANITARY SEWER PIPE TO BE SCH. 40 (PVC) FOR 6" OR LESS AND SDR-35 (PVC) FOR 8" MEETING ASTM SPECIFICATIONS D1785 & D2665 UNLESS OTHERWISE NOTED.
  - ALL SEWERS SHALL HAVE CLASS A BEDDING IN ACCORDANCE WITH CITY OF BRYAN.
  - ALL SANITARY SEWERS CROSSING ABOVE OR BELOW WATERLINES WITH 6 INCHES TO 9 FEET CLEARANCE SHALL HAVE A 20' JOINT OF 150 PSI AWWA C-900 SDR-18 P.V.C. SANITARY SEWER PIPE CENTERED ON WATERLINE, EXCEPT WHERE DUCTILE IRON PIPE IS USED.
  - SANITARY SEWER MANHOLE RIMS OUTSIDE OF PROPOSED PAVING WILL BE SET 3'-6" ABOVE THE SURROUNDING LEVEL FINISHED GRADE AFTER PAVING WITH SLOPED BACKFILL ADDED FOR STORM WATER DRAINAGE AWAY FROM MANHOLE RIM.
  - PRIVATE SANITARY SEWERS ARE TO BE PRIVATELY OWNED, OPERATED AND MAINTAINED BY SERVICED PROPERTY OWNER.

- WATER NOTES:**
- WATER MAINS/METER CONSTRUCTION SHALL BE IN ACCORDANCE WITH CITY OF BRYAN FOR WATER MAIN CONSTRUCTION AND MATERIALS AND SPECIFICATION FOR WATER TAPS AND SERVICE LINES 3/4" THROUGH 2" AND FOR LARGE METERS AND SPRINKLER CONNECTIONS WITH LATEST ADDENDA AND AMENDMENTS THERETO.
  - 1 1/2" THRU 3" WATER MAIN SHALL BE SCH. 40 PVC PIPE.
  - ALL WATER MAINS SHALL HAVE 6" OF BANK SAND ENVELOPE AND SHALL BE BACKFILLED TO A MINIMUM COMPACTED DEPTH OF 6" OVER THE TOP OF THE PIPE TO PROVIDE A COMPACTED ENCASUREMENT.
  - CONTRACTOR SHALL PROVIDE FOR A MINIMUM HORIZONTAL CLEARANCE OF 9' (NINE FEET) AND MINIMUM 2' (TWO FEET) BETWEEN OUTSIDE OF WATERLINES AND OUTSIDE EDGE OF SANITARY SEWER MANHOLES OR LINES.
  - CONTRACTOR SHALL PROVIDE ADEQUATE THRUST BLOCKING TO WITHSTAND TEST PRESSURE SPECIFIED IN SPECIFICATION FOR WATER MAIN CONSTRUCTION AND MATERIALS WITH LATEST ADDENDA AND AMENDMENTS THERETO.
  - ALL WATERLINES TO BE DISINFECTED IN CONFORMANCE WITH AWWA C-651
  - BACKFLOW PREVENTION DEVICE MUST BE INSTALLED ON IRRIGATION WATER METER. CONTRACTOR SHALL INSTALL DEVICE APPROVED FOR USE BY CITY OF BRYAN.

- GENERAL NOTES**
- LOCATIONS OF THE EXISTING UTILITIES ARE BASED ON RECORDS FROM SAID UTILITY COMPANIES AND ARE HORIZONTALLY FIELD LOCATED ONLY. THE CONTRACTORS SHALL BE RESPONSIBLE FOR DETERMINING ACTUAL LOCATION.
  - CONTRACTOR TO UNCOVER AND MARK UTILITY LINES BEFORE CONSTRUCTION.
  - CONTRACTOR SHALL BEAR ALL RESPONSIBILITY AND COST OF REPAIR OR REPLACEMENT OF EXISTING UTILITIES, DAMAGED OR INTERRUPTED AS A RESULT OF THIS CONSTRUCTION PROJECT.
  - CONTRACTOR SHALL NOTIFY THE PROJECT ENGINEER AND THE OWNER OF ANY DAMAGED OR INTERRUPTED UTILITIES IMMEDIATELY.
  - ALL WATER LINES AND APPURTENANCES SHALL BE INSTALLED IN ACCORDANCE WITH LOCAL WATER STANDARD PIPELINE MATERIALS AND CONSTRUCTION SPECIFICATIONS, LATEST EDITION.
  - EXISTING UTILITIES TO REMAIN ARE TO BE ADJUSTED TO MATCH PROPOSED GRADE.
  - CONTRACTOR SHALL NOTIFY PROJECT ENGINEER AND Matagorda COUNTY MUD NO. 41 OPERATOR PRIOR TO BEGINNING WORK.
  - ALL AREAS WITHIN THE PAVED AREAS ARE TO RECEIVE A GRAVEL BASE TO PROVIDE EROSION CONTROL IF WORK IS NOT PROGRESSING IN AN ORDERLY MANNER. A RATE OF 135 TONS/ACRE IS TO BE APPLIED WITHIN TWO WEEKS OF FINAL GRADING.
  - ALL AREAS NOT WITHIN THE PAVED AREA ARE TO RECEIVE LOOSE STRAW TO PROVIDE EROSION CONTROL IF WORK IS NOT PROGRESSING IN AN ORDERLY MANNER. A RATE OF 15 TONS/ACRE IS TO BE APPLIED WITHIN TWO WEEKS OF FINAL GRADING.
  - AFTER NEW INLETS ARE CONSTRUCTED, INSTALL INLET PROTECTION PER DETAIL.
  - CONTRACTOR WILL CONTROL AND PREVENT OFF-SITE TRACKING OF CONSTRUCTION RUNOFF AND SEDIMENT TO ADJACENT PROPERTY AND PUBLIC ROADS.
  - CONTRACTOR IS TO PROTECT EXISTING STORM DRAINAGE SYSTEM
  - CONTRACTOR TO CONFORM TO ALL CONSTRUCTION STORM WATER AND EROSION CONTROL PERMITTING REQUIREMENTS BY "EPA PHASE II STORM WATER REGULATIONS" AS ADMINISTERED BY THE TEXAS COMMISSION OF ENVIRONMENTAL QUALITY. WHERE PERMITTING IS REQUIRED, A COPY OF THE NOTICE OF INTENT SHALL BE PROVIDED TO THE LOCAL MUNICIPAL AUTHORITY.
  - CONTRACTOR SHALL LOCATE ALL EXISTING UTILITIES IN ACCORDANCE WITH THE TEXAS UNDERGROUND FACILITIES DAMAGE PREVENTION ACT. THIS LAW REQUIRES THAT THE CONTRACTOR MAKE A TELEPHONE CALL TO THE TEXAS ONE-CALL SYSTEM AT 1-800-344-8377 (811) AT LEAST TWO WORKING DAYS PRIOR TO EXCAVATION TO ENSURE THAT ANY EXISTING UTILITIES CAN BE LOCATED.
  - CONTRACTOR TO CONSTRUCT ALL ACCESS RAMPS AND PAVING TO ADA STANDARDS. VERIFY.
  - TREES TO REMAIN ARE TO BE PROTECTED FROM DAMAGE DURING CONSTRUCTION.
  - EXCESS EXPORTS SHALL BE STOCKPILED AT LOCATION APPROVED BY OWNER AND CONFIRMED BY ENGINEER OF RECORD.

ISSUE FOR:  
FOR INTER REVIEW ONLY  
BID ONLY  
PERMITS SET  
CONSTRUCTION SET

**REVISIONS:**

NO.	DATE	DESCRIPTION

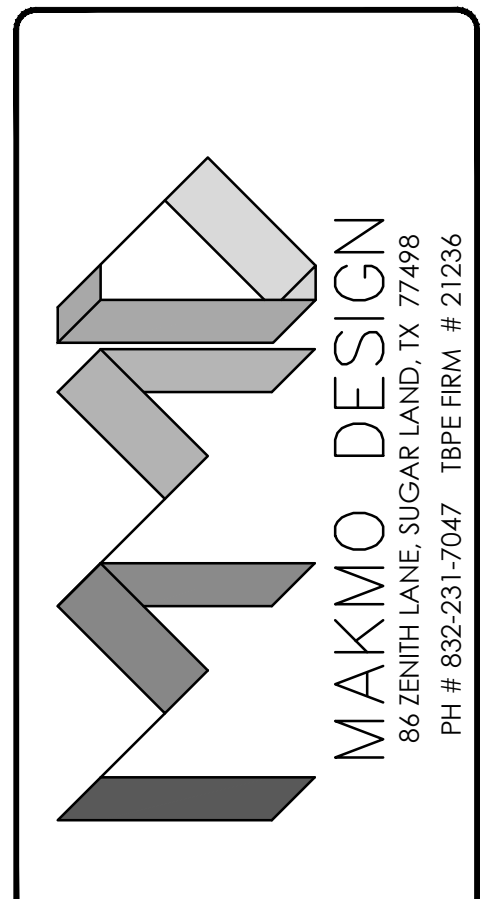

**PROPOSED C STORE & GAS STATION**  
LOCATED AT  
**1001 W VILLA MARIA RD, BRYAN, TX 77801**

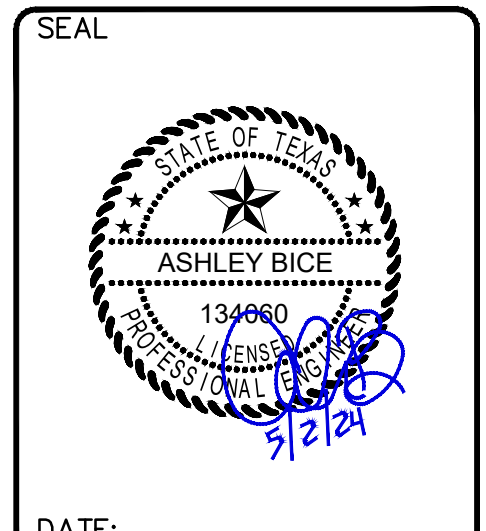

DATE:

PROJECT NUMBER 23-000  
SCALE 1" = 30'  
DRAWN BY R.R  
CHECKED BY A.Z  
SHEET TITLE :



**UTILITY PLAN**

DRAWING NUMBER:  
**C-4.0**

WEST VILLA MARIA ROAD  
(100' R.O.W. ASPHALT PAVEMENT / CONCRETE CURB & GUTTER)

FORESTWOOD DRIVE  
(60' R.O.W. ASPHALT PAVEMENT / CONCRETE CURB & GUTTER)

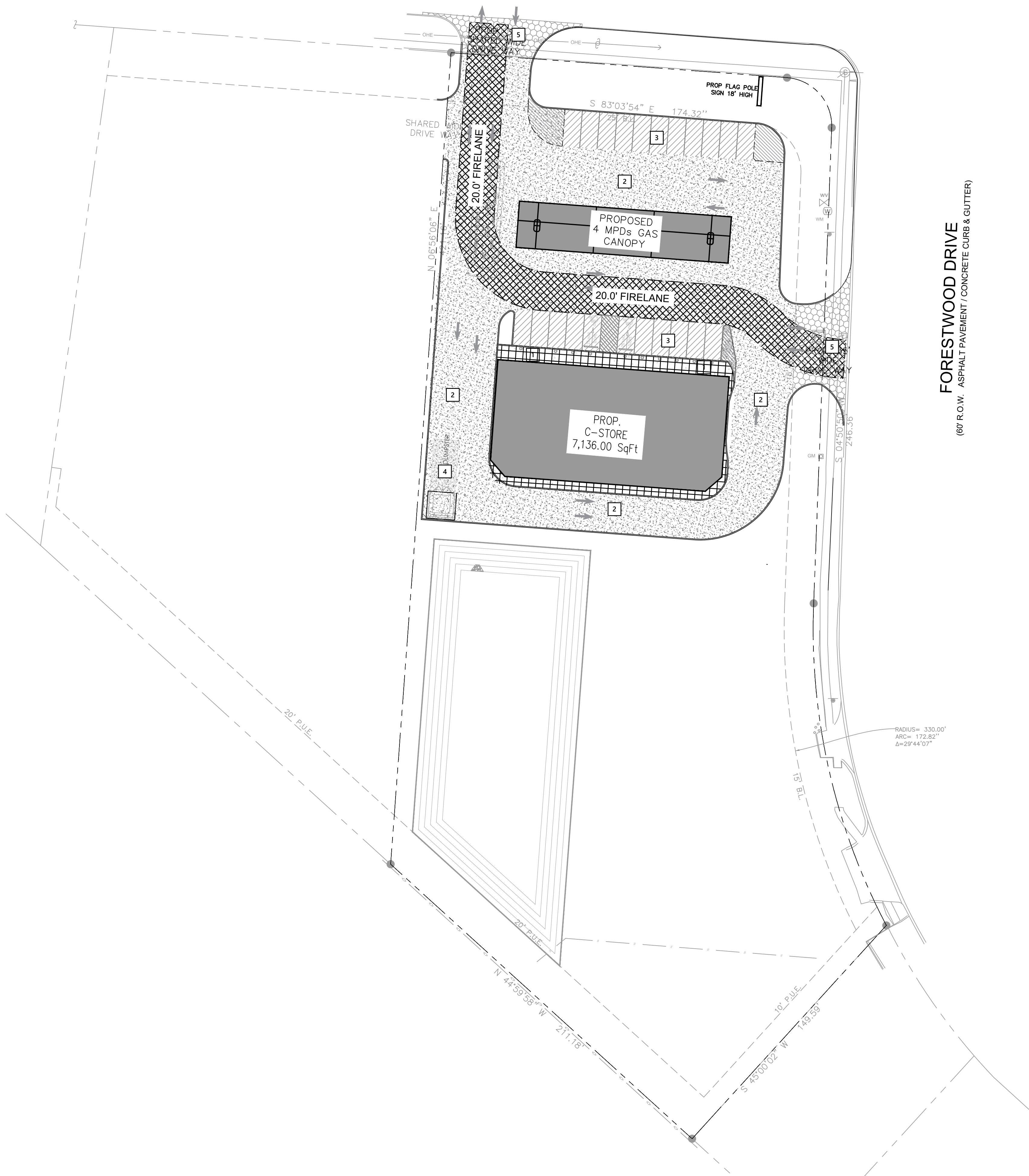

- GENERAL NOTES**
- LOCATIONS OF THE EXISTING UTILITIES ARE BASED ON RECORDS FROM SAID UTILITY COMPANIES AND ARE HORIZONTALLY FIELD LOCATED ONLY. THE CONTRACTORS SHALL BE RESPONSIBLE FOR DETERMINING ACTUAL LOCATION.
  - CONTRACTOR TO UNCOVER AND MARK UTILITY LINES BEFORE CONSTRUCTION.
  - CONTRACTOR SHALL BEAR ALL RESPONSIBILITY AND COST OF REPAIR OR REPLACEMENT OF EXISTING UTILITIES, DAMAGED OR INTERRUPTED AS A RESULT OF THIS CONSTRUCTION PROJECT.
  - CONTRACTOR SHALL NOTIFY THE PROJECT ENGINEER AND THE OWNER OF ANY DAMAGED OR INTERRUPTED UTILITIES IMMEDIATELY.
  - ALL WATER LINES AND APPURTENANCES SHALL BE INSTALLED IN ACCORDANCE WITH LOCAL WATER STANDARD PIPELINE MATERIALS AND CONSTRUCTION SPECIFICATIONS, LATEST EDITION.
  - EXISTING UTILITIES TO REMAIN ARE TO BE ADJUSTED TO MATCH PROPOSED GRADE.
  - CONTRACTOR SHALL NOTIFY PROJECT ENGINEER PRIOR TO BEGINNING WORK.
  - ALL AREAS WITHIN THE PAVED AREAS ARE TO RECEIVE A GRAVEL BASE TO PROVIDE EROSION CONTROL IF WORK IS NOT PROGRESSING IN AN ORDERLY MANNER. A RATE OF 1.5 TONS/ACRE IS TO BE APPLIED WITHIN TWO WEEKS OF FINAL GRADING.
  - ALL AREAS NOT WITHIN THE PAVED AREA ARE TO RECEIVE LOOSE STRAW TO PROVIDE EROSION CONTROL IF WORK IS NOT PROGRESSING IN AN ORDERLY MANNER. A RATE OF 1.5 TONS/ACRE IS TO BE APPLIED WITHIN TWO WEEKS OF FINAL GRADING.
  - AFTER NEW INLETS ARE CONSTRUCTED, INSTALL INLET PROTECTION PER DETAIL.
  - CONTRACTOR WILL CONTROL AND PREVENT OFF-SITE TRACKING OF CONSTRUCTION RUNOFF AND SEDIMENT TO ADJACENT PROPERTY AND PUBLIC ROADS.
  - CONTRACTOR IS TO PROTECT EXISTING STORM DRAINAGE SYSTEM.
  - CONTRACTOR TO CONFORM TO ALL CONSTRUCTION STORM WATER AND EROSION CONTROL PERMITTING REQUIREMENTS BY "EPA PHASE II STORM WATER REGULATIONS" AS ADMINISTERED BY THE TEXAS COMMISSION OF ENVIRONMENTAL QUALITY. WHERE PERMITTING IS REQUIRED, A COPY OF THE NOTICE OF INTENT SHALL BE PROVIDED TO THE LOCAL MUNICIPAL AUTHORITY.
  - CONTRACTOR SHALL LOCATE ALL EXISTING UTILITIES IN ACCORDANCE WITH THE TEXAS UNDERGROUND FACILITIES DAMAGE PREVENTION ACT. THIS LAW REQUIRES THAT THE CONTRACTOR MAKE A TELEPHONE CALL TO THE TEXAS ONE-CALL SYSTEM AT 1-800-344-8377 (811) AT LEAST TWO WORKING DAYS PRIOR TO EXCAVATION TO ENSURE THAT ANY EXISTING UTILITIES CAN BE LOCATED.
  - CONTRACTOR TO CONSTRUCT ALL ACCESS RAMP AND PAVING TO ADA STANDARDS. VERIFY.
  - TREES TO REMAIN ARE TO BE PROTECTED FROM DAMAGE DURING CONSTRUCTION.
  - EXCESS EXPORTS SHALL BE STOCKPILED AT LOCATION APPROVED BY OWNER AND CONFIRMED BY ENGINEER OF RECORD.

**LEGEND**

1		SIDEWALK (5" WITH #3 BARS @ 18" O.C.)
2		DRIVING PVMT (6" WITH #4 BARS @ 18" O.C.)
3		PARKING PVMT (6" WITH #4 BARS @ 24" O.C.)
4		DUMPSTER PAD (7" WITH #5 BARS @ 12" O.C.)
5		CONCRETE APRON (8" WITH #4 BARS @ 18" O.C.)

- CONCRETE PAVING NOTES:**
- ALL CONCRETE SHALL BE IN ACCORDANCE TO THE BUILDING CODE REQUIREMENT IN THE ACI 318-85. ALL CONCRETE SHALL MEET THESE MINIMUM SPECIFICATION.
- SLUMP: 3-4"  
PAVING: CONCRETE STRENGTH: 3500 PSI @ 28 DAYS  
MAX COARSE AGGREGATE SIZE: 1"
- FORM WORK DESIGN IS THE RESPONSIBILITY OF THE CONTRACTOR AND SHALL NOT BE REMOVED UNTIL THE CONCRETE HAS GAINED SUFFICIENT STRENGTH TO CARRY ITS OWN WEIGHT PLUS APPLIED CONSTRUCTION LOADS.
  - CONCRETE PLACEMENT SHALL BE ACCOMPLISHED BY DIRECT CHUTE FROM THE MIXER TRUCK, CRANE AND BUCKET OR BY PUMPING TO ITS FINAL POINT OF DEPOSIT. CONCRETE SHALL NOT BE DUG BY HAND MORE THAN 5 FEET.
  - TO PREVENT EXCESS AND UNCONTROLLED CRACKING, CONTROL JOINTS SHOULD BE PROVIDED AT 12' MAX. SPACING IN EACH DIRECTION. CONTROL JOINTS MAY BE SAW CUT, METAL KEYWAY OR OF REMOVABLE STRIP TYPE. EXPANSION JOINT SHALL BE PLACED NO MORE THAN 45' MAX. EXPANSION JOINTS SHALL THEN BE FILLED WITH AN ELASTOMERIC JOINT FILLER MATERIAL. SEE PLAN MATERIAL EXACT LOCATION OF JOINTS. FOR SIDEWALKS, PROVIDE EXPANSION JOINTS @ 20' O.C. AND CONTROL JOINTS @ 5' O.C. MAX.
- PAVING METHODS:**
- 5" CONCRETE PAVING REINFORCED WITH #3 BARS @ 18" O.C.E.W. OVER 6" SUBGRADE WITH ABOUT 6% LINE-FLY ASH BY DRY UNIT WEIGHT STABILIZED. (SIDEWALK/WALK WAYS)
  - 6" CONCRETE PAVING REINFORCED WITH #4 BARS @ 24" O.C.E.W. OVER 6" SUBGRADE WITH ABOUT 6% LINE-FLY ASH BY DRY UNIT WEIGHT STABILIZED. (PARKING AREA)
  - 6" CONCRETE PAVING REINFORCED WITH #4 BARS @ 18" O.C.E.W. OVER 6" SUBGRADE WITH ABOUT 6% LINE-FLY ASH BY DRY UNIT WEIGHT STABILIZED. (DRIVING ISLE)
  - 7" CONCRETE PAVING REINFORCED WITH #5 BARS @ 12" O.C.E.W. OVER 9" SUBGRADE WITH ABOUT 6% LINE-FLY ASH BY DRY UNIT WEIGHT STABILIZED. (DUMPSTER LOCATION)
  - 8" CONCRETE PAVING REINFORCED WITH #4 BARS @ 18" O.C.E.W. OVER 8" LIME STABILIZED SUBGRADE. 60' MAX HEADER SPACING. MIN 16" LAP SPlice (CONCRETE DRIVEWAY APRON)
  - 8" BLACK BASE, 8" STABILIZED LIME SUBGRADE, 2.5-3" TYPE D
- REINFORCING STEEL NOTES:**
- REINFORCING BARS SHALL CONFORM TO ASTM A-615, GRADE 60. BARS SHOULD BE NEW, CLEAN AND FREE OF DIRT, RUST OR OIL.
  - DETAILING AND FABRICATION OF REINFORCING BARS SHALL BE IN ACCORDANCE WITH THE MANUAL OF STANDARD PRACTICE, ACI-318-80, UNLESS SHOWN OTHERWISE CONTINUOUS BARS 30 BAR DIAMETERS AT SPLICES, 12" MIN.
  - REINFORCING BARS MAY NOT BE WELDED WITHOUT THE APPROVAL OF THE CIVIL ENGINEER.
  - PROVIDE NECESSARY TIES AND BAR SUPPORTS AS REQUIRED BY THE MANUAL OF STANDARD PRACTICE, ACI 318-80, CHAPTER 3. BRICK, ROCK OR MASONRY BLOCKS ARE NOT ACCEPTABLE SUPPORTS. CHAIRS AND BOLSTERS FOR DIRECTLY OVER EARTH, POLY SHEETS SHALL BE EQUIPPED WITH BOTTOM BEARING PLATES.
  - CONCRETE COVERAGE FOR THE REINFORCING STEEL SHALL COMPLY WITH THE ACI 318-85 CODE, ARTICLE 7.7.1, EXCEPT WHERE STATED SPECIFICALLY OTHERWISE.
- SITE PREPARATION NOTES:**
- THE CONTRACTOR SHALL FOLLOW THE GUIDELINES SET FORTH WITHIN THE GEOTECHNICAL REPORT FOR SITE PREPARATION AND PAVING AND IS ADVISED TO GET IT SUPERVISED AND/OR INSPECTED WITH THE GEOTECHNICAL FIRM AS REQUIRED. THE MINIMUM SITE COMPACTION UNDER PAVING AND OVER UTILITIES SHALL BE 95% OR HIGHER ON PROCTOR WITH FILL PLACED IN 8" LIFTS. SUBGRADE MUST BE LIME STABILIZED AND REQUIRE 7% HYDRATED LIME BY DRY UNIT WEIGHT. THE STABILIZED CLAYS SHOULD BE COMPACTED TO A MINIMUM OF 95% OF MAXIMUM DENSITY IN A MOISTURE CONTENT RANGE OF -1% TO +4% OF THE SOULIME MIXTURE'S OPTIMUM MOISTURE CONTENT AS DETERMINED BY ASTM D-698.

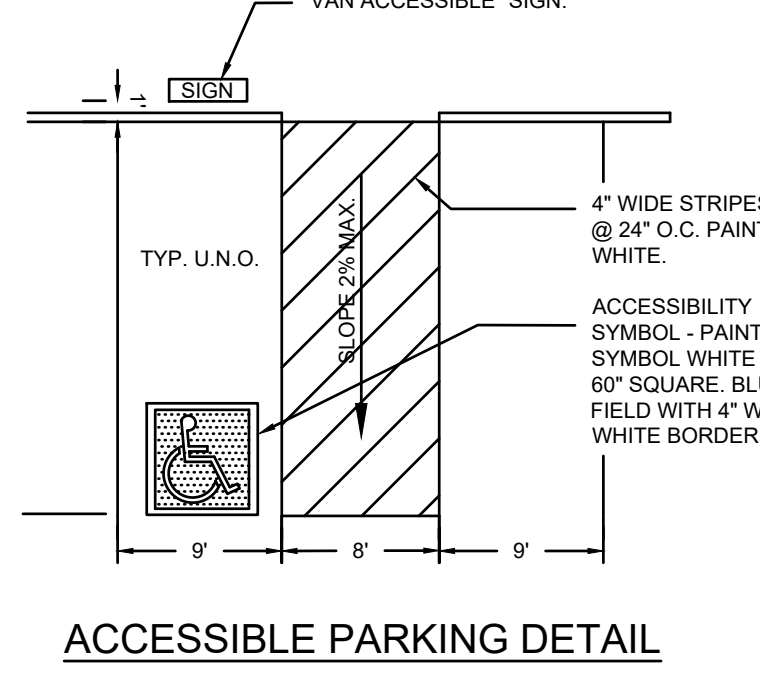
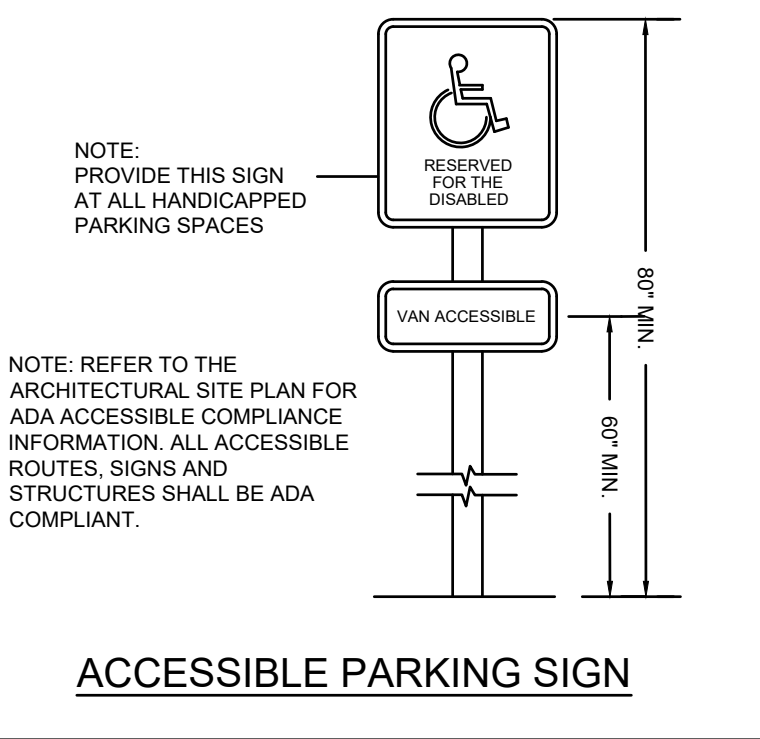

ISSUE FOR:  
FOR INTER REVIEW ONLY  
BID ONLY  
PERMITS SET  
CONSTRUCTION SET

**REVISIONS:**

NO.	DATE	DESCRIPTION

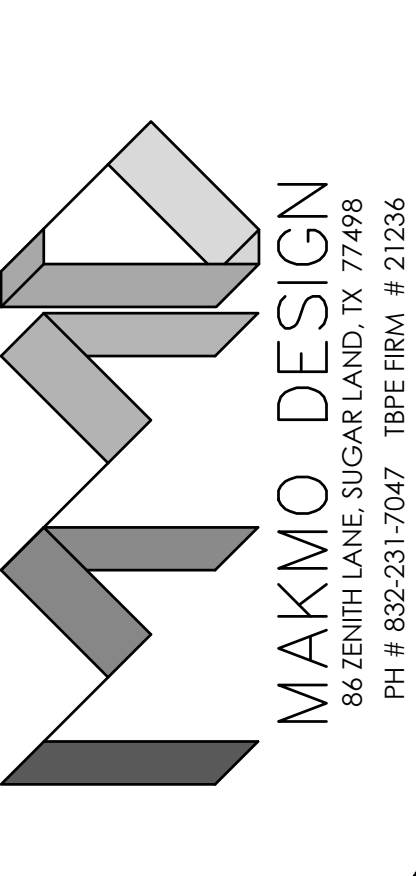

**PROPOSED C STORE & GAS STATION**  
LOCATED AT  
**1001 W VILLA MARIA RD, BRYAN, TX 77801**



DATE: \_\_\_\_\_  
PROJECT NUMBER 23-000  
SCALE 1" = 30'  
DRAWN BY R.R.  
CHECKED BY A.Z.  
SHEET TITLE :

**PAVING PLAN**

DRAWING NUMBER:  
**C-5.0**

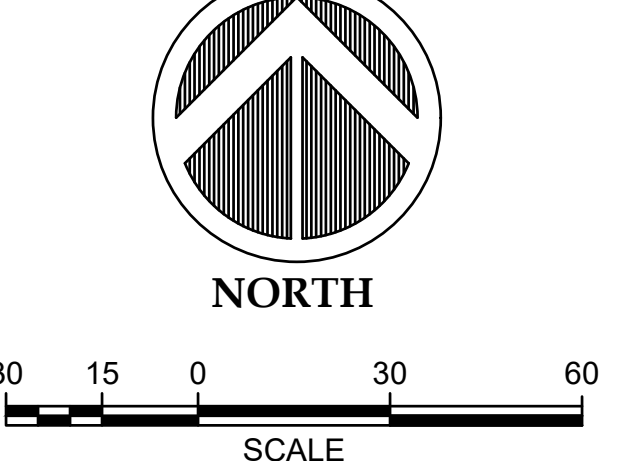



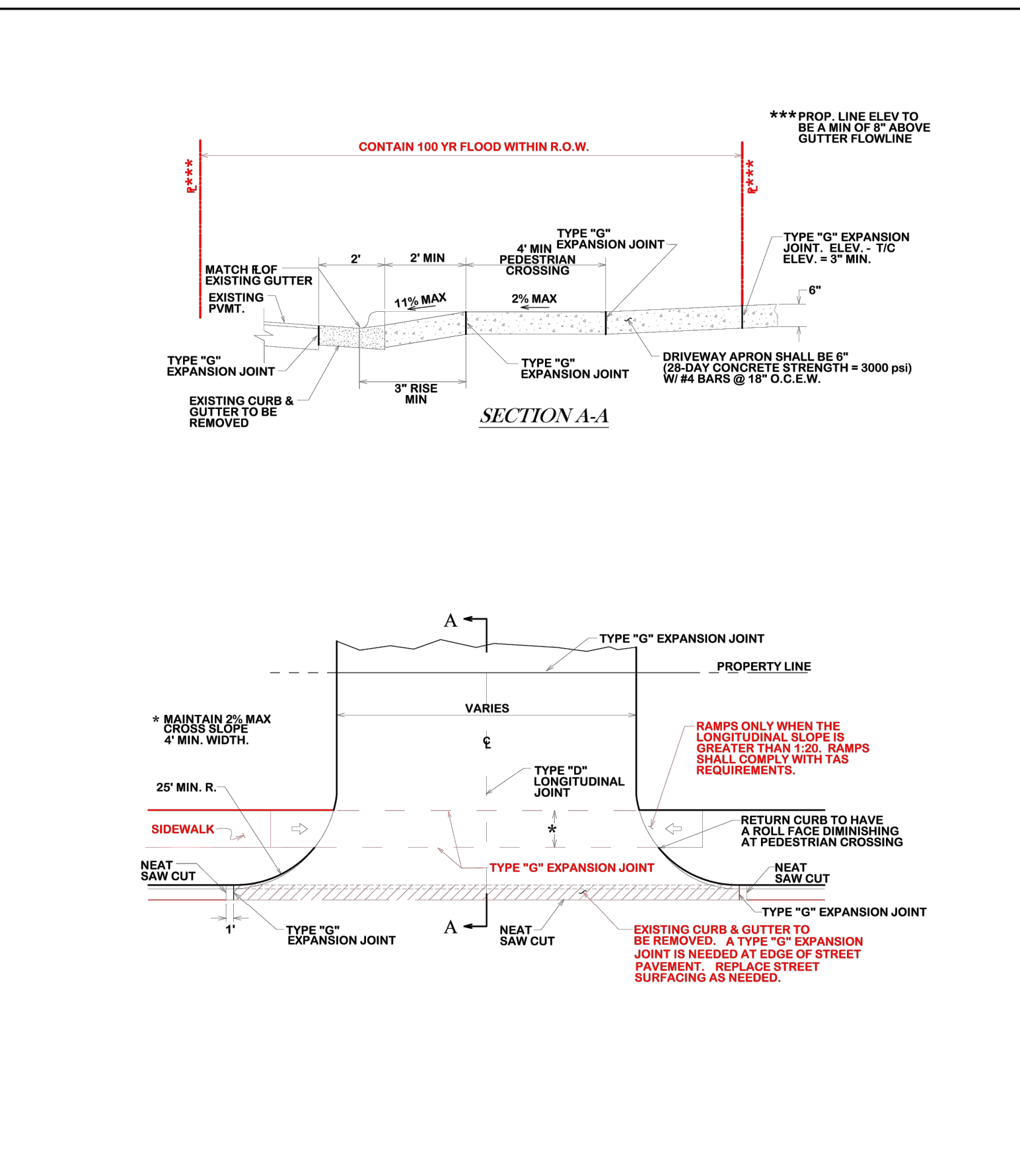

	<b>COMMERCIAL DRIVEWAY</b>			
	DATE	B/C'S UNIFIED STANDARD DETAIL	DETAIL NO.	
	FEB. 2021	ST2-03		

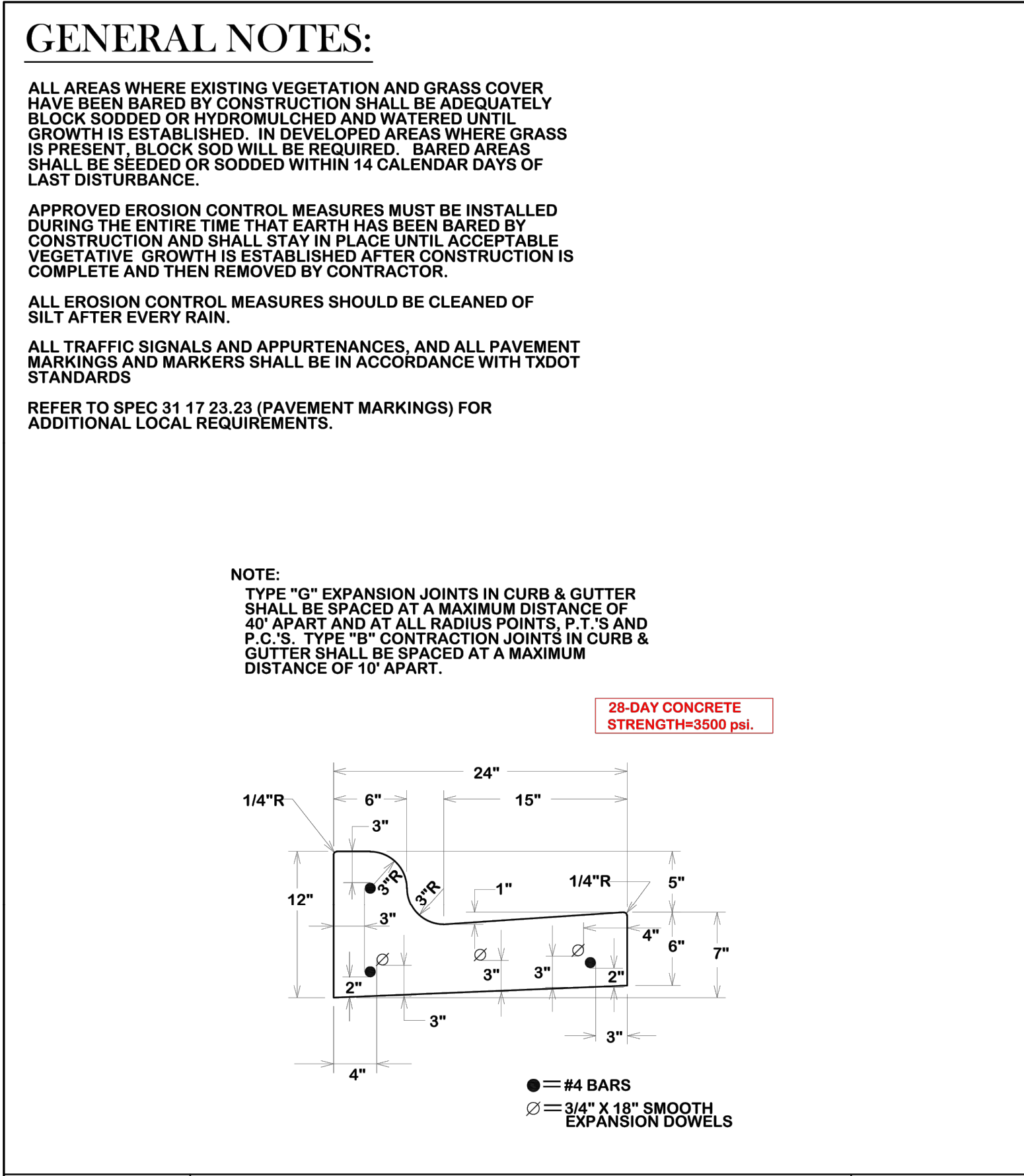

	<b>TYPICAL COMBINED CURBS &amp; GUTTER SECTION</b>			
	DATE	B/C'S UNIFIED STANDARD DETAIL	DETAIL NO.	
	FEB. 2021	ST1-01		

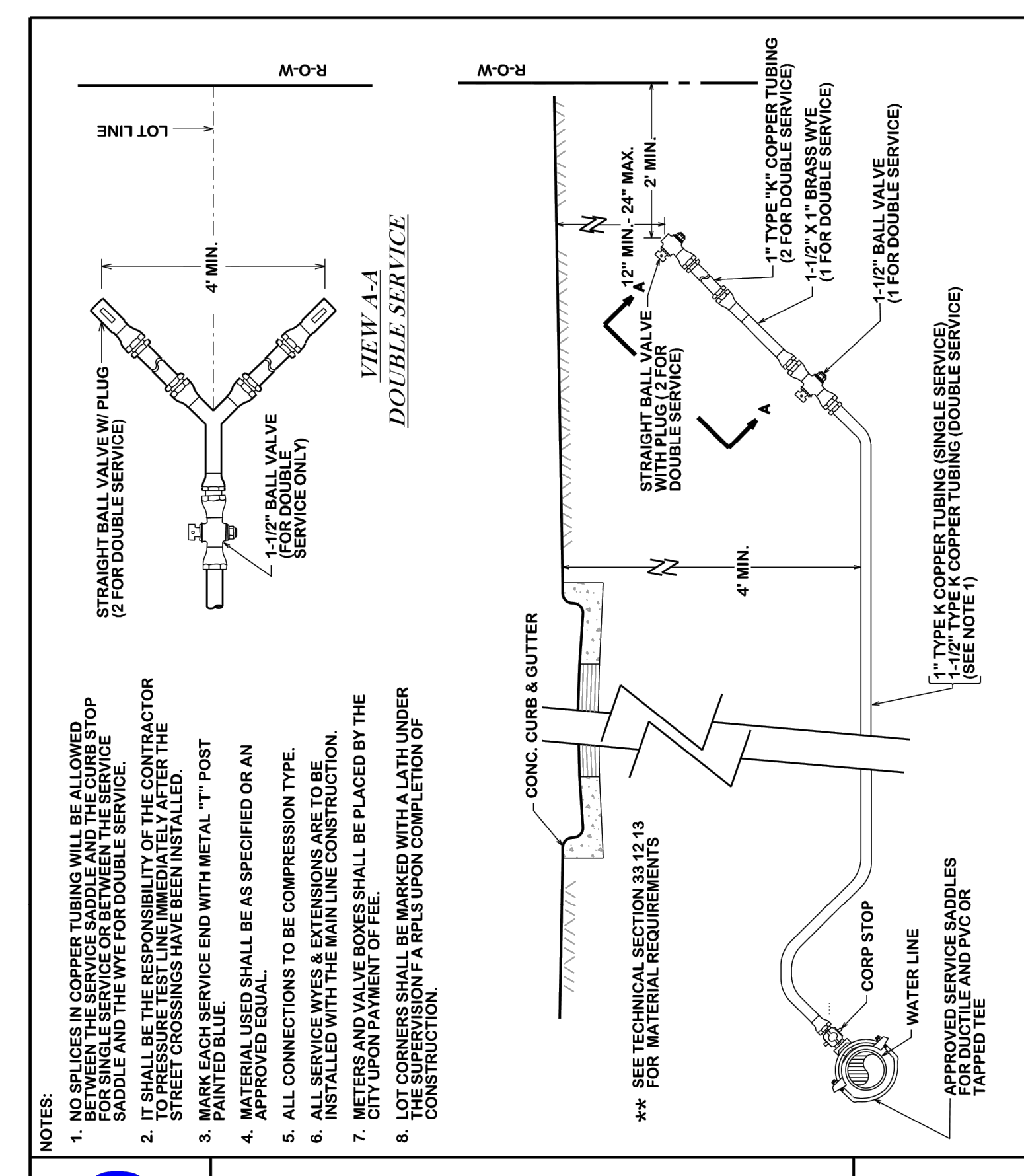

	<b>NEW WATER SERVICE (SHORT AND LONG SIDE)</b>			
	DATE	B/C'S UNIFIED STANDARD DETAIL	DETAIL NO.	
	JAN. 2009	W2-01		

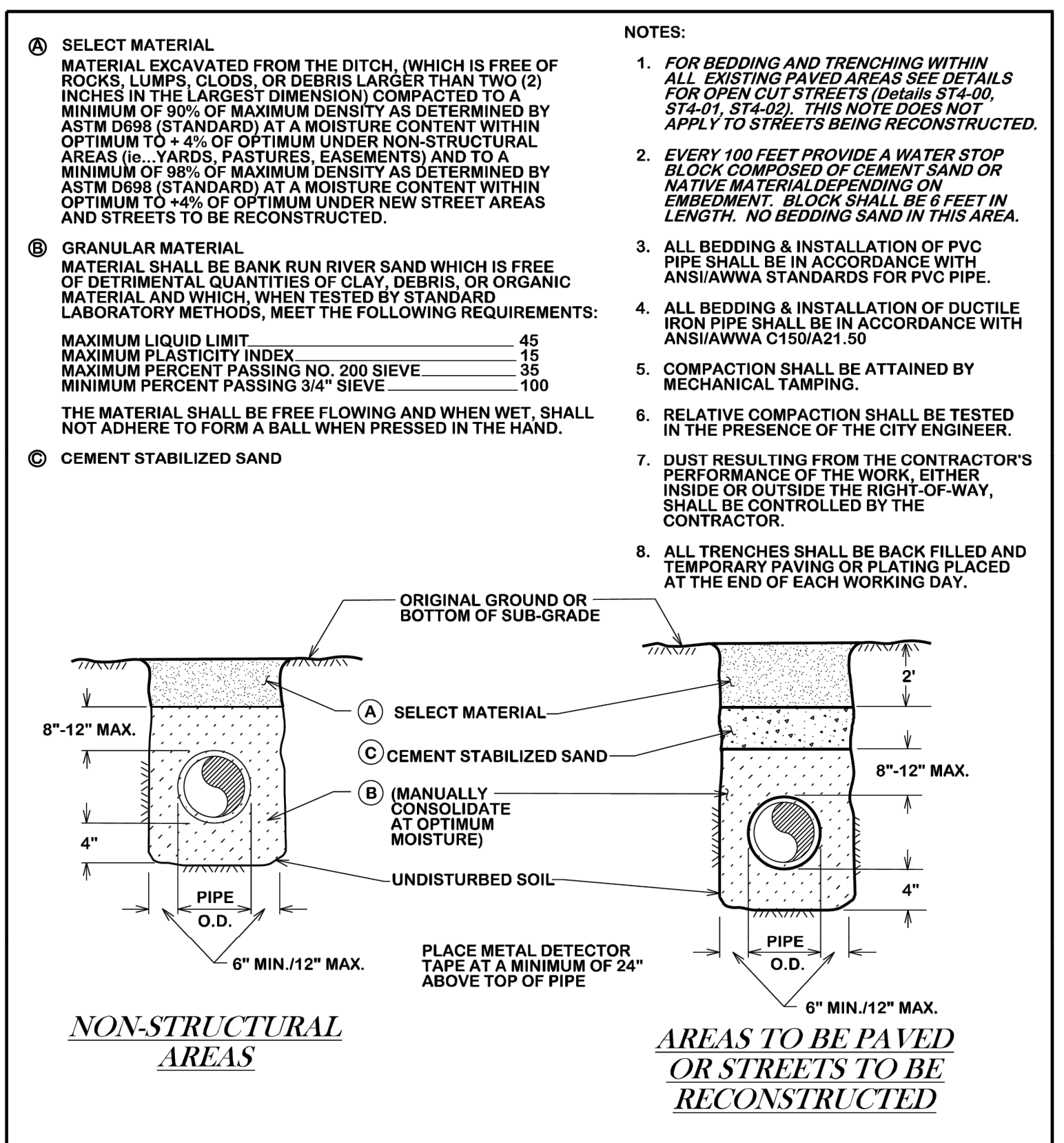

	<b>BEDDING AND TRENCH FOR DI PIPE &amp; PVC PIPE WITHIN NON-STRUCTURAL OR NEW PAVED AREAS</b>			
	DATE	B/C'S UNIFIED STANDARD DETAIL	DETAIL NO.	
	AUG. 2012	W4-02		

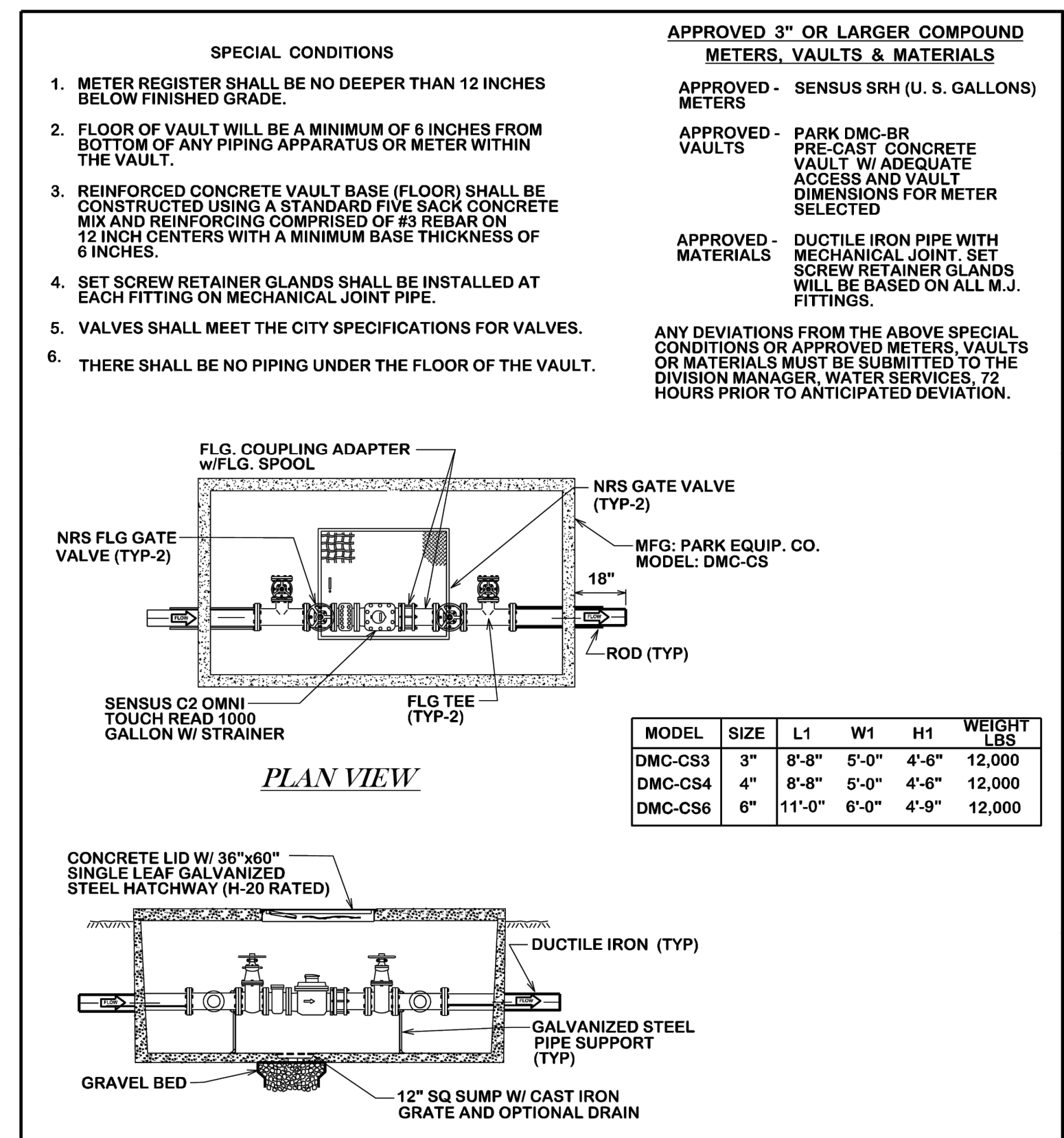

	<b>CITY OF COLLEGE STATION METER VAULT ASSEMBLY</b>			
	DATE	B/C'S UNIFIED STANDARD DETAIL	DETAIL NO.	
	AUG. 2012	W5-00		

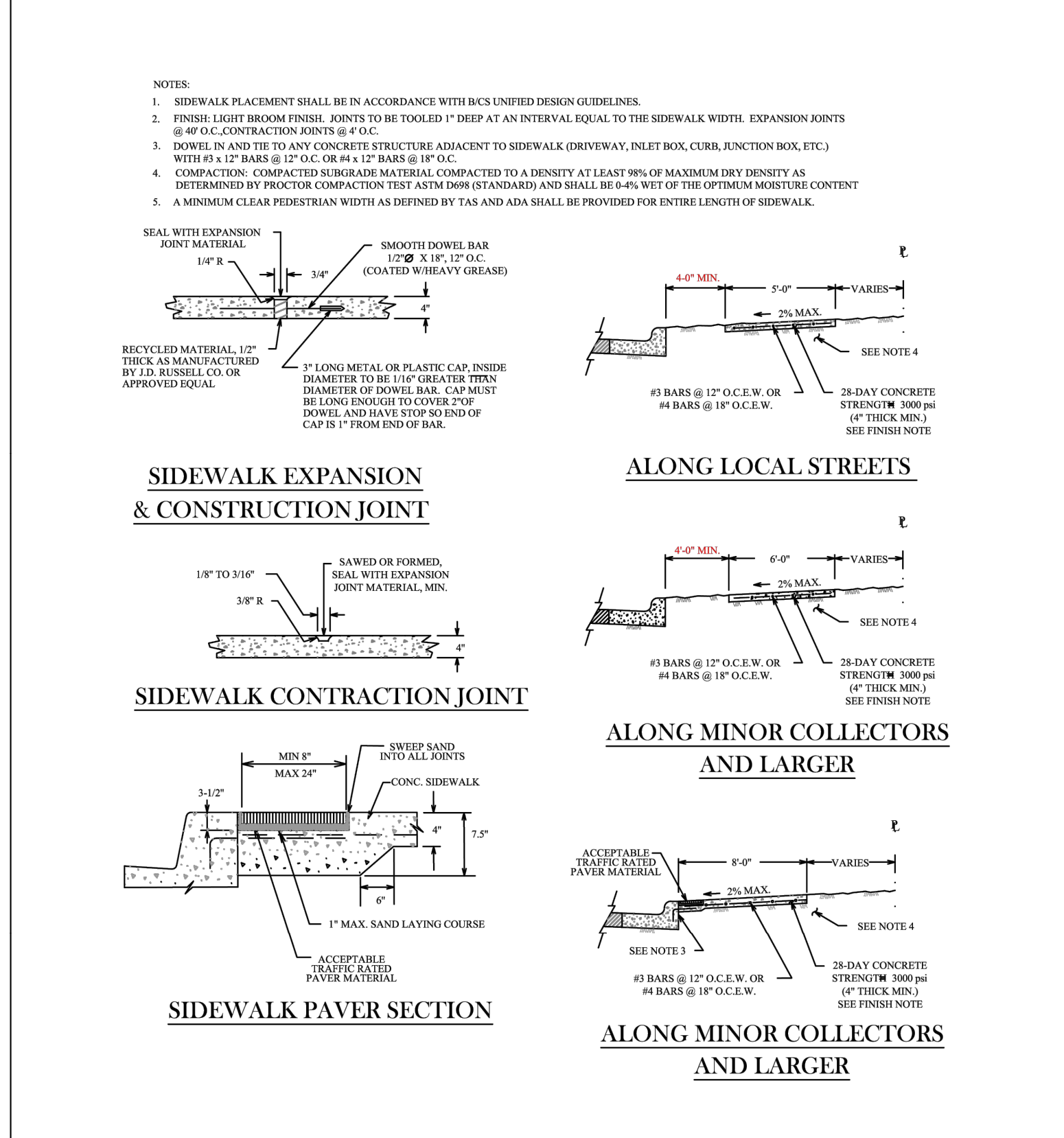

	<b>CONCRETE SIDEWALK</b>			
	DATE	B/C'S UNIFIED STANDARD DETAIL	DETAIL NO.	
	DECEMBER 2020	SW1-02		

ISSUE FOR:  
FOR INTER REVIEW ONLY  
BID ONLY  
PERMITS SET  
CONSTRUCTION SET

REVISIONS:		
NO.	DATE	DESCRIPTION

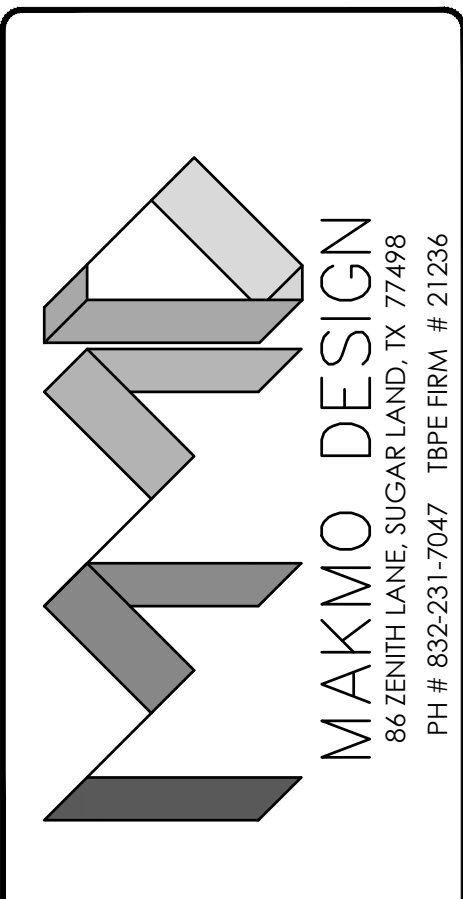

**PROPOSED C STORE & GAS STATION**  
LOCATED AT  
**1001 W VILLA MARIA RD, BRYAN, TX 77801**

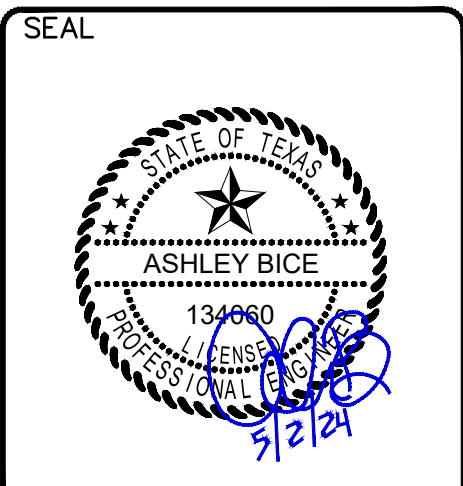

DATE:  
PROJECT NUMBER 23-000  
SCALE  
DRAWN BY R.R.  
CHECKED BY A.Z.  
SHEET TITLE :

**CONSTRUCTION DETAILS**

DRAWING NUMBER:  
**C-6.1**

NOTE:  
 TEMPORARY DEVICES AROUND STORM DRAINS ARE USED TO DETAIN AND/OR FILTER SEDIMENT LAID RUMPS. THE PROTECTION ALLOWS SEDIMENT TO SETTLE PRIOR TO DISCHARGE INTO A STORM DRAIN INLET OR CATCH BASIN.  
 SEDIMENT CONTROL LOGS ARE TO BE USED ON EXISTING CURB INLETS WHICH ARE LOCATED ADJACENT TO TRAVEL Lanes WITHIN THE DISTURBED LIMITS OF A PROJECT AS SHOWN ON THE PLANS.  
 SEDIMENT CONTROL LOGS ARE TO BE INSTALLED AND MAINTAINED PER THE MANUFACTURER'S INSTRUCTIONS AND PROPERLY WEIGHTED IN ORDER TO REMAIN SECURE. INSTALLATION MUST MEET THE CONSTRUCTION INSPECTOR'S APPROVAL.  
 SEDIMENT CONTROL LOGS ARE TO BE CONSTRUCTED OF WOOD FIBER, SYNTHETIC FIBERS OR OTHER SUITABLE MATERIAL SUFFICIENT TO RETAIN ITS SHAPE AND ENCASED IN A UV STABILIZED FILTERING MEDIA OF SUFFICIENT STRENGTH TO RETAIN SEDIMENT.  
 SEDIMENT CONTROL LOGS ARE TO BE APPROVED BY THE ENGINEER PRIOR TO INSTALLATION.  
 SAND BAGS SHALL NOT BE USED.

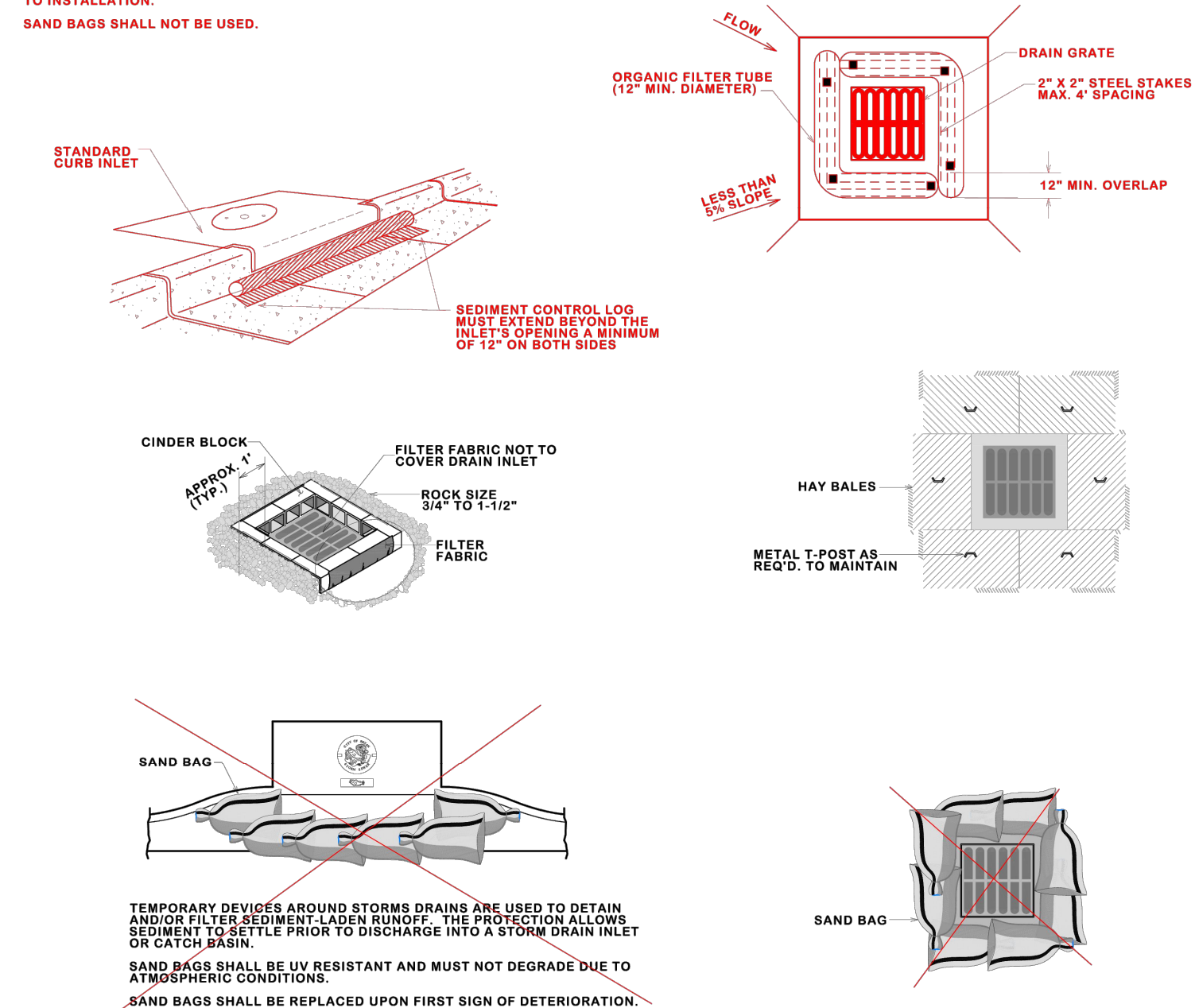

**STORM DRAIN INLET PROTECTION**

DATE: **DECEMBER 2020** B/C'S UNIFIED STANDARD DETAIL: **SWPP1-00**

CITY OF BRYAN CITY OF COLLEGE STATION

NOTE:  
 DRESS WITH ADDITIONAL STONE AS NEEDED. STONE IS TO BE MAINTAINED SO AS TO PREVENT CONSTRUCTION TRAFFIC FROM TRACKING MUD ONTO ADJACENT PUBLIC STREETS.

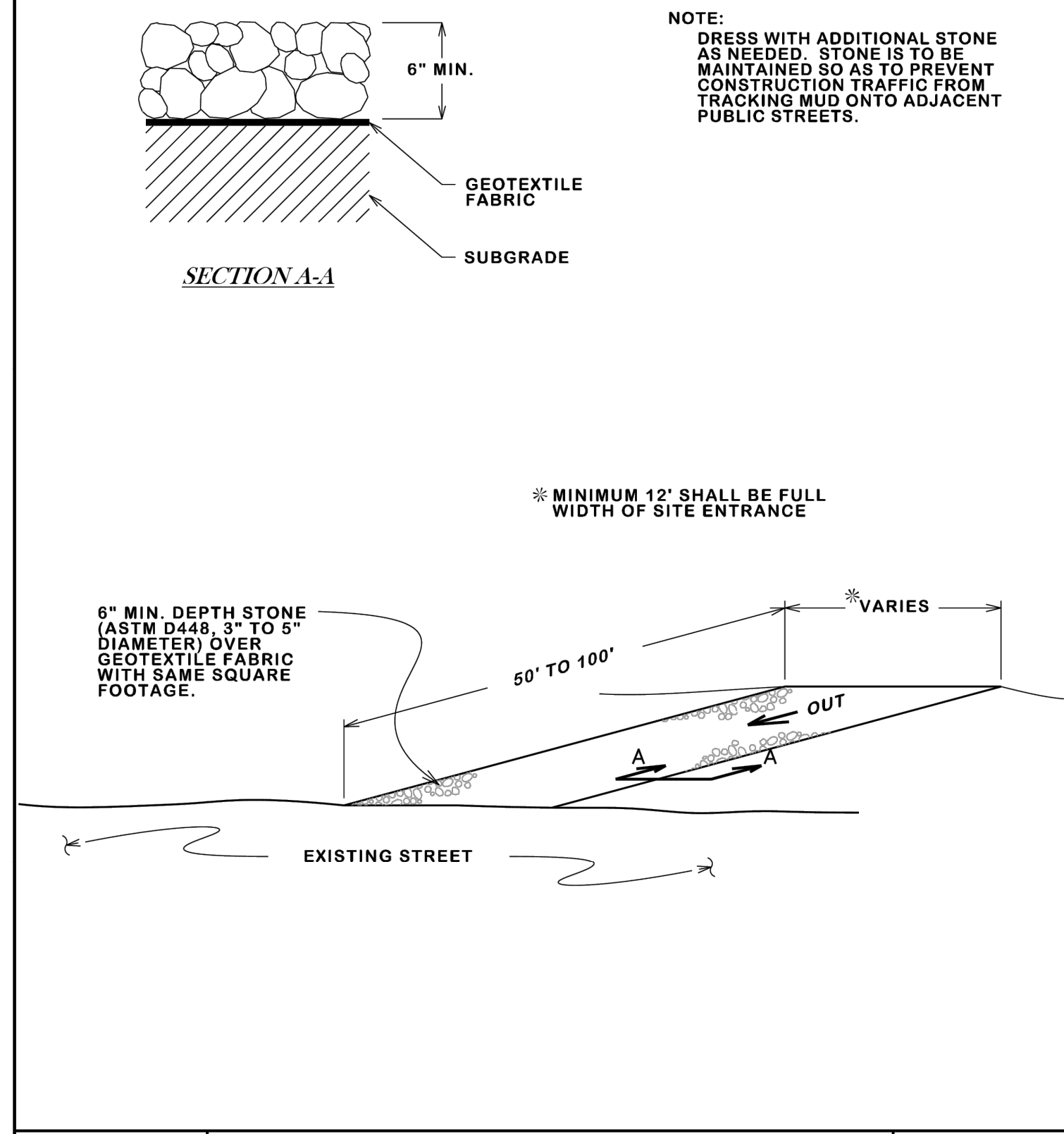

**CONSTRUCTION EXIT SLIT CONTROL**

DATE: **AUG. 2012** B/C'S UNIFIED STANDARD DETAIL: **SWPP1-02**

CITY OF BRYAN CITY OF COLLEGE STATION

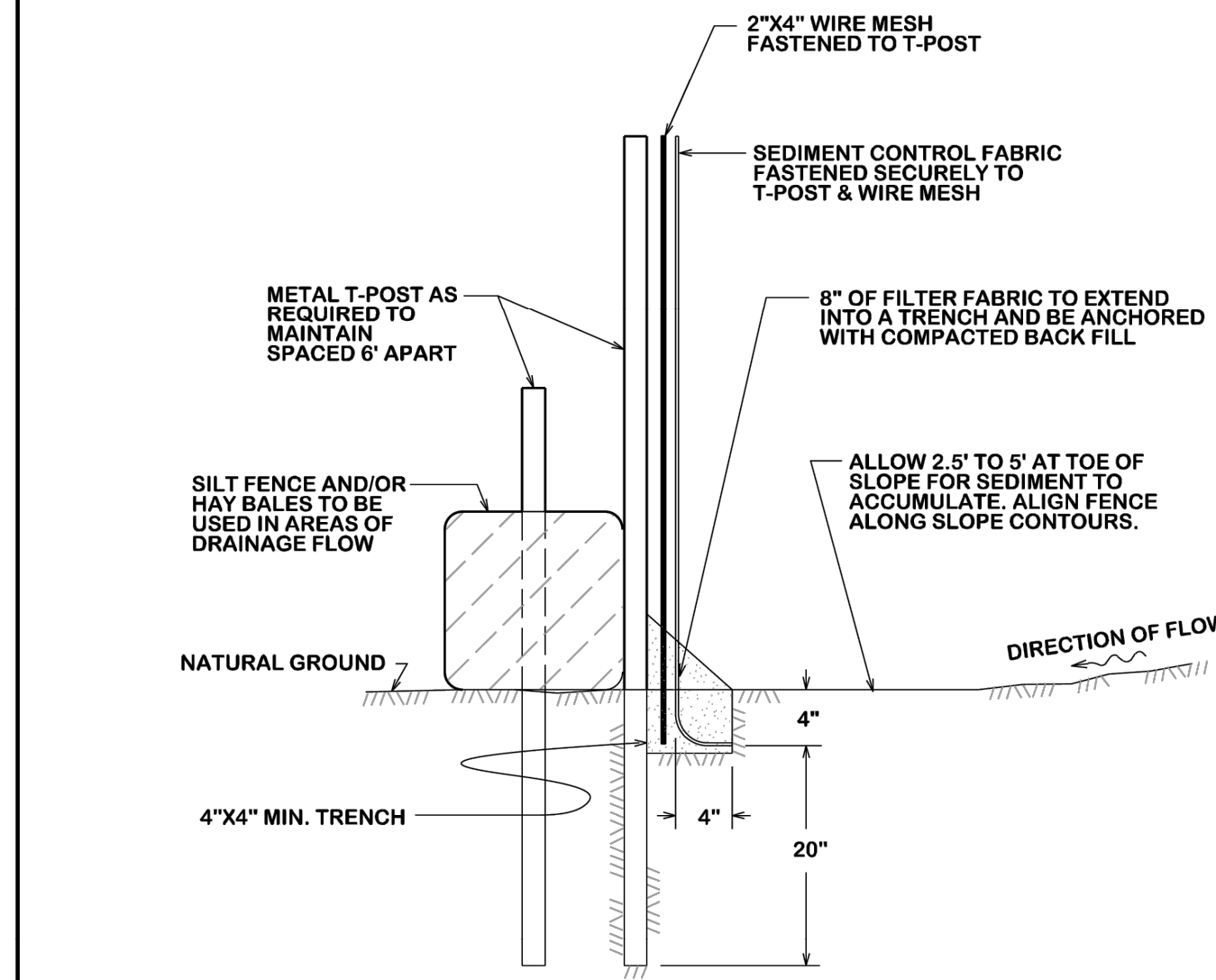

**SILT FENCE ASSEMBLY**

DATE: **AUG. 2012** B/C'S UNIFIED STANDARD DETAIL: **SWPP1-03**

CITY OF BRYAN CITY OF COLLEGE STATION

NOTE:  
 POST A SIGN READING "CONCRETE WASH OUT PIT" NEXT TO THE PIT.  
 VERBALLY INSTRUCT THE CONCRETE TRUCK DRIVERS WHERE THE PIT IS AND TO WASH OUT THEIR TRUCKS IN THE PIT AND NO WHERE ELSE.  
 NO WASHING OUT OF CONCRETE TRUCKS OR WASHING OF SHREDDERS FROM EXPOSED AGGREGATE CONCRETE INTO STORM DRAINS, OPEN DITCHES, STREETS, OR STREAMS IS ALLOWED.  
 EXCESS CONCRETE IS NOT ALLOWED TO BE DUMPED ON-SITE, EXCEPT IN DESIGNATED TEMPORARY CONCRETE WASHOUT PIT AREAS.  
 ON-SITE TEMPORARY CONCRETE WASHOUT AREAS WILL BE LOCATED AT LEAST 50 FEET FROM STORM DRAINS, OPEN DITCHES, OR WATER BODIES AS DETERMINED IN THE FIELD.  
 TEMPORARY CONCRETE WASHOUT FACILITIES WILL BE CONSTRUCTED AND MAINTAINED TO CONTAIN ALL LIQUID AND CONCRETE WASTE GENERATED BY WASHOUT OPERATIONS.  
 WASHOUT FACILITIES WILL BE CLEANED OUT OR REPLACED ONCE THE WASHOUT IS FULL. PLASTIC LINING MATERIAL WILL BE MINIMUM OF 10 MIL POLYETHYLENE SHEETING AND WILL BE FREE OF HOLES, TEARS, OR OTHER DEFECTS.  
 WHEN WASHOUT FACILITIES ARE NO LONGER REQUIRED FOR WORK, THE WASHOUT CONCRETE WILL BE REMOVED AND DISPOSED OF OFF-SITE. MATERIALS USED TO CONSTRUCT TEMPORARY CONCRETE WASHOUT FACILITIES WILL BE REMOVED FROM THE SITE AND DISPOSED OF IN ACCORDANCE WITH ALL APPLICABLE REGULATIONS.  
 CONSTRUCT ENTRY ROAD AND BOTTOM OF WASHOUT AREA TO SUPPORT EXPECTED LOADINGS FROM TRUCK EQUIPMENT.

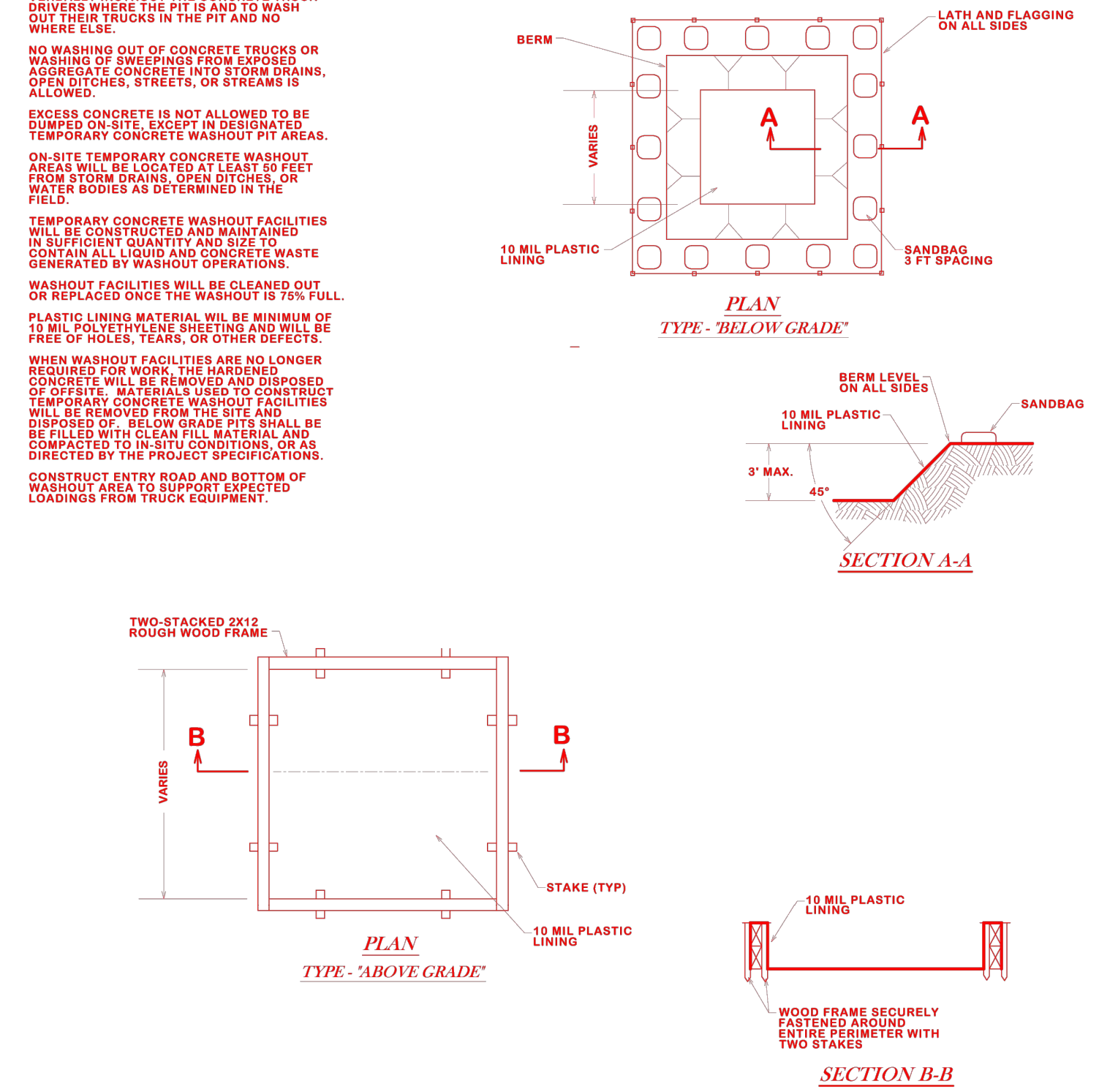

**CONCRETE WASHOUT**

DATE: **DECEMBER 2020** B/C'S UNIFIED STANDARD DETAIL: **SWPP1-04**

CITY OF BRYAN CITY OF COLLEGE STATION

ISSUE FOR:  
 FOR INTER REVIEW ONLY  
 BID ONLY  
 PERMITS SET  
 CONSTRUCTION SET

REVISIONS:

NO.	DATE	DESCRIPTION

**MAKMO DESIGN**  
 86 ZENITH LANE, SUGAR LAND, TX 77498  
 PH # 832-231-7047 TBP# FIRM # 21236

**PROPOSED C STORE & GAS STATION**  
 LOCATED AT  
 1001 W VILLA MARIA RD, BRYAN, TX 77801

SEAL

DATE:

PROJECT NUMBER: 23-000  
 SCALE:  
 DRAWN BY: R.R.  
 CHECKED BY: A.Z.  
 SHEET TITLE:

**SWPPP DETAILS**

DRAWING NUMBER:  
**C-6.2**